

PowerCore AC Cabinet User Manual



Copyright © Jiangsu Weiheng Intelligent Technology Co., Ltd. All rights reserved.

Unauthorized excerpts, reproduction or distribution in any form, in whole or in part, of this document by any organization or individual without Weiheng's written consent is strictly prohibited.

Trademark Statement

UHES and other WEIHENG trademarks are owned by Jiangsu Weiheng Intelligent Technology Co., Ltd. All other trademarks or registered trademarks referenced herein are the property of their respective owners.

Note: Your purchase of the products, services or features is subject to WEIHENG's commercial contracts and terms and conditions. As a result, all or part of the products, services or features described in this document may not be consistent with your specific purchase or use. Unless otherwise agreed in the contract, WEIHENG makes no statements or warranties, express or implied, with respect to the contents of this document.

This document may be updated from time to time due to product version upgrades or other factors. Unless otherwise agreed, this document is provided as a guide only and no representations, information or recommendations contained herein constitute a warranty of any kind, either express or implied.

Jiangsu Weiheng Intelligent Technology Co., Ltd.

Address: Luoshe Town, Huishan District, Wuxi, Jiangsu Province, China (at the intersection of Jianghai West Road and Luonan Avenue)

Postal Code: 214000

Website: www.whes.com

Introduction

Overview





This document provides guidance on the installation, electrical connection, commissioning, and troubleshooting methods for the AC-XXXkW-XXXX AC Cabinet (hereinafter referred to as the "energy storage system"). Prior to installation, operation of the energy storage system (ESS), please read this manual carefully, ensuring comprehension of the safety information and familiarity with the system's functions and features.

Users

This manual is applicable to power station operators and qualified electrical technicians.

Symbol Convention

In this document, the following symbols may be used with the meanings described below.

Symbol	Description
	It indicates a hazard with a high level of risk that, if not avoided, will result in death or serious injury.
	It indicates a hazard with a moderate level of risk that, if not avoided, could result in death or serious injury.
	It indicates a hazard with a low level of risk that, if not avoided, could cause minor or moderate injury.
	It is used to convey warning information related to equipment or environmental safety. If not avoided, it may result in damage to equipment, loss of data, degradation of equipment performance, or other unpredictable consequences. The "BEWARE" symbol does not refer to personal injury.
	It is used to emphasize important/critical information, best practices, and tips. The "NOTE" symbol is not a safety warning and does not refer to personal injury, equipment damage, or environmental hazards.

Modification Record

The revision history tracks the description of all updates to the document. The latest version of the document contains all changes from previous revisions.

Document Edition: 01 (2025-1-20)

V1.0

Table of Contents

Introduction	iii
1 Safety Precautions	1
1.1 General Safety	1
1.2 Personnel Requirements	5
1.3 Storage and Installation Environment Requirements	7
1.4 Loading/Unloading and Transport Requirements	3
1.5 Electrical Safety	5
1.6 Mechanical Safety.....	7
1.7 Maintenance.....	10
1.8 Emergency Protocol.....	11
2 Product Introduction	12
2.1 Model Description	12
2.2 Functions and Features	13
2.3. Appearance.....	14
2.4 Components	15
2.5. Working Principle	23
2.6 Application Scenarios	25
3 Site Requirements	26
3.1 Site Selection Requirements.....	26
3.2 Forklift Requirements	27
4 Equipment Installation	28
4.1 Pre-Installation Preparation	28
4.2 Cable Selection	32
4.3 Installing the ESS and Cables	33
5 System Power-On	48
5.1 Pre-Power-On Inspection	48
5.2 Power-On Procedure	49
6 Power-On Commissioning (PANGU-LITE)	51
6.1 Preparation and PANGU LITE Access.....	51
6.2 HMI Description.....	52
6.3 Startup Procedure	57
6.4 Shutdown Procedure	58
7 System Power-Off	59
8 Technical Data	60

9. Product Maintenance	63
9.1 Terminology Definition.....	63
9.2 Requirements for Normal System Operation.....	63
9.3 Requirements for Intermittent System Operation.....	63
9.4 Requirements for Long-Term System Storage	63
9.5 Battery Maintenance Instructions.....	65
9.6 Liquid Chiller System Maintenance and Service Requirements.....	66
A Crimping OT/DT Terminals	67
B How to Repaint.....	70
C How to Recycle Used Batteries	75
D Contact Details	76
E Abbreviations.....	77
F Install.....	错误!未定义书签。
Appendix 1.....	错误!未定义书签。

1 Safety Precautions

1.1 General Safety

Declaration

Please thoroughly read this manual before installing, operating, and maintaining the equipment, and follow the markings present on the equipment, as well as all safety precautions outlined in this manual.

The "BEWARE", "CAUTION", "WARNING", and "DANGER" instructions contained in this manual do not cover all safety considerations that need to be observed, but are only intended to supplement all safety precautions. Weiheng disclaims any liability for damages resulting from failure to comply with general safe operation requirements or from violation of safety standards applicable to the design, production, and use of the equipment.

This equipment must be used in an environment that meets the design specifications, otherwise the equipment may fail, resulting in equipment malfunctions, component damage, personal safety accidents, property losses, etc., which are not covered by the quality warranty.

Be sure to install, operate and maintain the equipment in accordance with local laws, regulations, and specifications. The safety precautions contained in this manual are intended only to supplement local laws and regulations.

Weiheng shall not be held liable in any of the following circumstances:

- Installing or operating the equipment in an environment that exceeds applicable international, national, or local standards;
- Failure to operate the equipment under the conditions specified in this manual;
- Unauthorized disassembly, modification of the product or alteration of the software codes;
- Failure to operate the equipment in accordance with the operating instructions and safety warnings present on the product or outlined in the document;

- Damage to the equipment caused by abnormal natural environment (force majeure, such as earthquake, fire, storm, flood, mudslide);
- Damage caused by the customer's failure to comply with transport and installation requirements;
- Damage caused by storage conditions not meeting the requirements specified in the product document;
- Damage to the hardware or data of the equipment due to customer negligence, improper operation or intentional damage;
- Damage to the system caused by third parties or customers, including relocation and installation of the system not in accordance with the requirements of this manual, and adjustment, modification, or removal of identification marks not in accordance with the requirements of this manual;
- Defects, failures or damage caused by acts, events, negligence or accidents beyond the reasonable control of the Seller, including power outages or electrical failures, theft, war, riots, civil commotion, terrorism, intentional or malicious damage, etc.

General Requirements



The equipment operates at high voltages and improper handling poses a risk of electric shock or fire, which may cause death, serious injury, or substantial property damage. Always operate according to instructions:

- Follow the operating procedures and safety precautions described in this manual and other relevant document.
- Follow warning labels, cautions, and protective measures affixed to the equipment.
- Use the correct tools as specified in this manual and be proficient in the proper use of the tools.
- Comply with the safety regulations of the power plant, such as implementing the operation ticket and work ticket system.
- No one except the operator is allowed to access the equipment. Temporary warning signs or fencing must be erected to isolate the area during operation of the equipment.
- All warning labels, cautions, and protective measures affixed to the equipment shall remain legible. Unauthorized alteration, damage, or obstruction of such safety information is strictly prohibited. Any illegible markings shall be replaced in a timely manner.

- Do not perform installation, wiring, maintenance and replacement operations while the equipment is powered on.
- Do not clean the electrical components inside the equipment with water.
- Check the equipment for damage, such as holes, dents or other signs of possible internal damage.
- Check that the pre-installed cables of the equipment are securely connected.
- Check that the equipment is free from displacement of internal components, or unauthorized modification of internal structure and installation procedures.
- Do not power on the equipment until it has been installed or approved by qualified personnel.
- Measure the voltage at the contact point before touching any conductor surface or terminal, and confirm that the protective grounding conductor of the equipment or parts to be repaired is securely grounded to ensure that there is no risk of electric shock.
- Immediately press the EMERGENCY STOP Button and notify the on-site management if any liquid ingress is detected in the equipment.
- Do not open the cabinet door while the system is operating.
- For the first power - on of the equipment or when working in the live main - circuit area, it is recommended to wear level 1 arc - resistant clothing.

 **CAUTION**

- Do not perform arc welding, drilling, or cutting operations on the equipment. Such operations may damage the sealing of the entire enclosure, the electromagnetic shielding performance of the equipment, the internal components and cables, and the metal chips generated during the operation may cause short circuits, affecting the equipment function or causing equipment damage.
- The casing temperature is elevated during operation of the equipment, posing a risk of burns. Avoid physical contact with the equipment.
- If, during operation of the equipment, a fault is detected that may cause personal injury or damage to the equipment, stop operation immediately, notify the person in charge, and take effective protective measures.
- Evacuate the area immediately if an audible/visual fire alarm is activated.
- Close and lock the cabinet door if the equipment has to be left temporarily unattended during the maintenance procedure.

 **BEWARE**

- All transport, transit, installation, wiring, and maintenance activities must comply with the applicable laws, regulations, and standards of the country/region where the work is performed.
- The materials to be prepared by the user and the tools required during operation must comply with the applicable laws, regulations, and standards of the country or region where the work is performed.
- Permission from the local power authority must be obtained before the equipment is connected to the grid.
- Before opening the cabinet door during installation, operation, and maintenance, be sure to remove any accumulated water, snow, or other debris from the top of the enclosure to prevent debris from falling into the enclosure.

 **NOTE**

- It is prohibited to reverse engineer, decompile, disassemble, dismantle, adapt, implant, or perform other derivative operations on the equipment software. It is not allowed to research the internal implementation of the equipment, obtain the source code of the equipment software, or steal intellectual property rights in any way, nor is it allowed to disclose the results of any performance tests of the equipment software.
- It is recommended that users prepare video recording devices to document the detailed process of installation, operation, and maintenance of the equipment.

1.2 Personnel Requirements

- Only qualified personnel are permitted to perform tasks related to the equipment, including transport, transit, installation, wiring, and maintenance. When operating the equipment, operators must wear personal protective equipment that complies with local safety requirements.
- Operators must have completed Weiheng's relevant training programs, passed the required examinations, and demonstrated professional knowledge of the ESS.

NOTE

Local regulations and industry standards shall be consulted for specific qualification requirements.

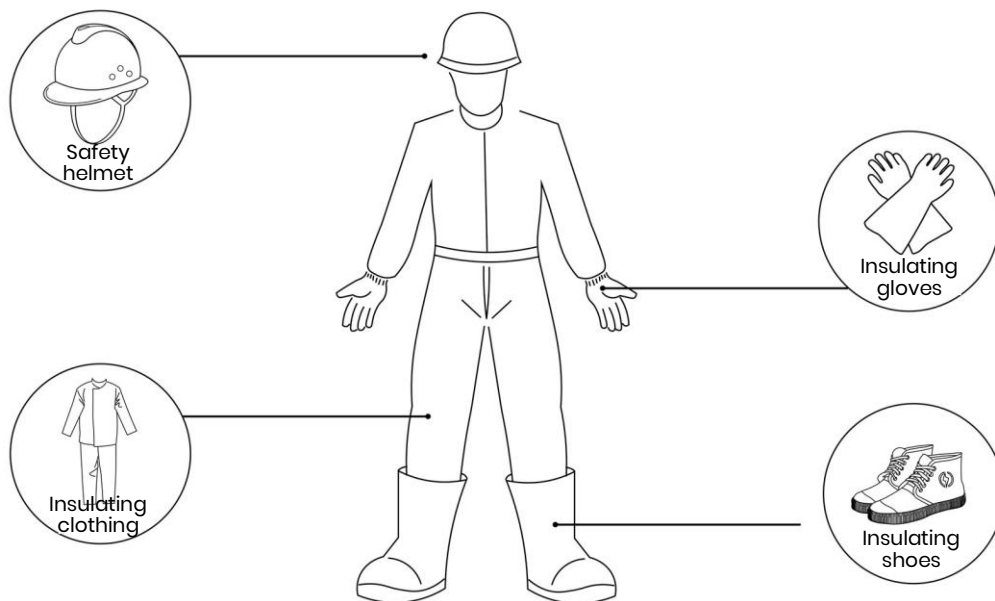

Figure 1-1 Illustration of Personal Protective Equipment

- Do not wear watches, bracelets, bangles, rings, necklaces, or other conductive items during installation, operation, or maintenance to prevent electric shock and burns.

- All transport, transit, installation, wiring, and maintenance activities must comply with the applicable laws, regulations, and standards of the country/region where the work is performed.
- It is important to ensure a comprehensive understanding of the construction and working principles of the entire ESS, and conduct all activities in accordance with the instructions provided in this manual.

1.3 Storage and Installation Environment Requirements

General requirements

 NOTE

- During the storage period, relevant evidence demonstrating compliance with product storage requirements, including temperature and humidity logs, photos of the storage environment, and inspection reports, must be properly maintained.
- The storage environment must be maintained in a clean and dry condition to prevent dust and moisture contamination. The equipment shall be protected from exposure to rain or groundwater.
- The ambient air must not contain any corrosive or flammable gases.
- Do not store the equipment in a tilted or inverted position.
- Equipment that has been stored for two years or more should be inspected and tested by qualified personnel before being put into use.

EES Storage Requirements

- Stacking storage is prohibited.
- Store the equipment on a level surface (for long-term or temporary storage).
- Keep the cabinet door securely closed.
- Storage temperature: -30 °C~+60°C, humidity: 5%RH~95%RH.
- The energy storage system contains lithium battery packs and should be kept in a dry, well-ventilated area, protected from direct sunlight, rain, and sources of intense infrared radiation, organic solvents, corrosive gases, and ignition.
- The warehouse keeper should be responsible for monitoring the ESS inventory on a monthly basis and reporting it to the planning department on a regular basis, and should arrange for personnel to inspect the ESS that has been stored for an extended period in a timely manner.
- ESS must be shipped based on the "first in, first out" principle.

Installation Environment Requirements

For site selection, please refer to **3.1 Site selection Requirements**. The following requirements must also be met during on-site installation:

- The installation layout of the ESS must meet the local standard requirements for fire protection distance or fire walls, including but not limited to the requirements of GB 51048-2014: Design Code for Electrochemical Energy Storage Power Station and NFPA 855 Standard for the Installation of Stationary Energy Storage Systems.
- It is prohibited to place the equipment in an environment with flammable, explosive gases, or smoke, and to operate the equipment in such an environment.
- The installation, use, and operation of outdoor equipment and cables (including but not limited to moving equipment, operating equipment and cables, plugging and unplugging outdoor signal interfaces, working at heights, and outdoor installation) is prohibited during thunderstorms, rain, snow, and winds of level 6 or above.
- It is recommended to install fences, walls, and other protective measures around the ESS, and erect safety warning signs to isolate the area and prevent unauthorized personnel from accessing the equipment during operation, which may result in personal injury or property damage.
- Do not block the vents and the chiller system during operation of the equipment to prevent fires caused by high temperatures.
- The equipment shall be installed in an area free from liquids and away from locations prone to condensation (such as under water pipes, air outlets) or prone to potential water leakage (such as under air conditioners, vents, machine room cable exit windows) to prevent liquid from entering the equipment and causing faults or short circuits.
- The installation site must be located away from sources of ignition, and no flammable or explosive materials shall be placed in the vicinity of the equipment.
- If the equipment is installed in an area with lush vegetation, periodic weeding and hardening of the soil beneath the equipment is required to prevent weed growth.

Elevated Work Requirements

- Implement proper safety protection measures, including using safety helmets, safety harnesses, waist safety belts, and attaching them to robust and reliable structural members. Do not hang them on moving unstable objects or sharp-edged metals, to prevent the hook from slipping and causing a fall accident.
- The elevated work site must be clearly designated as a restricted, hazardous area with prominent markings to deter unauthorized access.
- The ground area directly beneath the elevated work zone must be kept clear of any stacked scaffolding, planks, or other debris. Ground personnel are prohibited from staying or passing directly below the high-altitude operation area.
- Do not throw objects from a high place to the ground or vice versa. All items must be transported using appropriate methods such as ropes, hanging baskets, overhead vehicles, or cranes.
- All scaffolding, planks, and work platforms utilized for elevated work must undergo a thorough safety inspection and certification prior to use, ensuring structural reliability and preventing scaffold overloading.
- Elevated work must be immediately suspended during rain or other potentially hazardous conditions. Thereafter, Weiheng's safety supervisor and relevant technicians must inspect all equipment and give approval before elevated work can be safely resumed.
- All edges and openings within the elevated work zone shall be outfitted with guardrails and markings to prevent the risks of accidental falls or step-through incidents.
- Securely carry all necessary apparatus and tools during operations to prevent accidental falls.
- If an elevated worker is found to be violating safety protocols and performing construction work improperly, the site supervisor or safety officer must immediately issue a warning and instruct the worker to make corrections. Work may not be resumed until the elevated worker is in full compliance with established operating specifications.

1.4 Loading/Unloading and Transport Requirements

BEWARE

This product has been certified to comply with UN38.3 (UN38.3: Section 38.3 of the sixth Revised Edition of the Recommendations on the Transport of Dangerous Goods: Manual of Tests and Criteria) and SN/T 0370.2-2009 Rules for the Inspection of Packing for Export Dangerous Goods - Part 2: Performance Test, and is consequently classified as a Class 9 Dangerous Good.

Shipment conditions:

battery cabinets must be inspected prior to shipment to ensure that the enclosure is intact and undamaged, the cabinet doors are properly closed and locked, no foreign objects are protruding from the interior, and no indications of smoke or burning are present. Failure to meet any of these criteria will result in the shipment being prohibited.

NOTE

- The AC cabinet must be inspected prior to shipment to ensure that the enclosure is intact and undamaged, the cabinet doors are properly closed and locked, no foreign objects are protruding from the interior, and no indications of smoke or burning are present. Otherwise, shipment is prohibited.
- During loading/unloading and transport, care should be taken to handle gently and provide moisture protection measures. Due to the influence of external environmental factors (such as temperature, transport and storage conditions), the product specifications are subject to the date of manufacture.
- The AC cabinet is not intended for railway or air transport methods.
- For sea transport, the International Maritime Dangerous Goods Code (IMDG) must be observed.
- For land transport, the requirements of the Authorization Dangerous Road (ADR) or JT/T 617-2018: Regulations concerning Road Transportation of Dangerous Goods must be followed.
- Comply with the regulatory requirements set forth by the transport authorities in the countries of origin, transit, and destination.
- Comply with international transport rules for dangerous goods and the regulatory requirements set forth by the transport authorities in relevant countries.
- Monitoring is required throughout the entirety of the transport process.
- Vehicle used for land transport must have sufficient load capacity (AC cabinet weight: approximately 2000 kg per unit).

- The speed limit for land transport is 80km/h on flat roads and 60km/h on rugged roads, with local traffic regulations taking precedence if they conflict with these guidelines.
- Stacking is prohibited during port handling and on-board transport. The following situations are strictly prohibited during transport: falling into water, dropping or mechanical impact, as well as inverting or overturning.

 **NOTE**

1. The battery cabinet falls or is mechanically impacted.
2. The battery cabinet is inverted or overturned.

If the above situation occurs, follow the emergency procedures in Section 1.8.

1.5 Electrical Safety

Wiring Requirements

- Do not push cables directly off the vehicle or otherwise mishandle them.
- Do not route cables through the air inlet/outlet of the equipment.
- Cables of the same type shall be bundled together, while cables of different types shall be spaced at least 30 mm apart without intertwining or crossing.
- If the site has to be left unattended temporarily after or during the wiring process, the cable openings must be immediately sealed using sealing mud to prevent the ingress of small animals.
- Cables used in high-temperature environments are susceptible to insulation aging and damage. A minimum clearance of 30 mm must be maintained between cables and heat-generating components or heat source peripheries.
- Select cables that are in compliance with local laws and regulations.
- Cable troughs and openings must be free of sharp edges and provided with appropriate protection.
- Cable conduits or openings shall be protected against damage from sharp edges or burrs.
- Cables used in the ESS must be firmly connected, well-insulated, and comply with the appropriate specifications.
- After wiring, the cables must be securely fixed using cable supports and clamps. For cables in backfilled soil areas, ensure they are in close contact with the ground to prevent deformation or damage during backfilling.
- At low temperatures, violent impact and vibration may cause the outer plastic sheath of the cables to become brittle and crack. To ensure construction safety, the following requirements shall be followed:
 - ◇ All cables must be laid and installed at temperatures above 0°C. Care should be taken when handling cables, especially in low-temperature environments.
 - ◇ If cables are stored at temperatures below 0°C, they must be placed at room temperature for at least 24 h prior to installation.

Grounding Requirements

- Do not damage grounding conductors.
- Do not operate the equipment without installed grounding conductors.
- For equipment requiring grounding, always install the protective ground wire first and remove it last.
- The main grounding body of the equipment must be permanently connected to the protective grounding network. Before operating the equipment, the electrical connection must be checked to ensure reliable grounding.
- The grounding impedance of the equipment shall meet the requirements specified in GB 50054 and any applicable local electrical standards.

AC/DC Operation Requirements

- Before installing or removing the power cord, turn off the power switch first.
- Prior to connecting the power cord, verify that the label on the power cord is correct.
- If the equipment has multiple inputs, all inputs shall be turn off and the equipment shall be completely de-energized before any work is performed.

Operation, Maintenance and Repair Safety Requirements

1. Turn off the circuit breaker before connecting or turn off any cables.
2. Place a "Do Not Close" warning sign on the open Button.
3. Use a voltage tester of the appropriate rating to verify the equipment is completely de-energized.
4. Cover or wrap any nearby live parts with insulating sheeting or tape.
5. Before performing any operation, maintenance or repair activities, connect the circuit to be repaired securely to the grounding circuit using a grounding wire.



- Prior to connecting cables, verify that the label on the cable is correct.
 - If the equipment has multiple inputs, all inputs shall be turn off and the equipment shall be completely de-energized before any work is performed.
-
6. After the repair is completed, remove the grounding wire between the repaired circuit and the grounding circuit.

1.6 Mechanical Safety

Transport Safety

i BEWARE

- This equipment must be lifted using a lifting frame.
- When using a forklift to move the equipment, ensure that the forklift has sufficient load capacity and that the center of gravity of the equipment is between the forklift legs to prevent personal injury and equipment damage;
- Forklift load capacity: ≥ 2 t;
- Recommended fork length: ≥ 1.8 m, fork width: 60cm~80cm, fork thickness: 25 mm~70 mm.

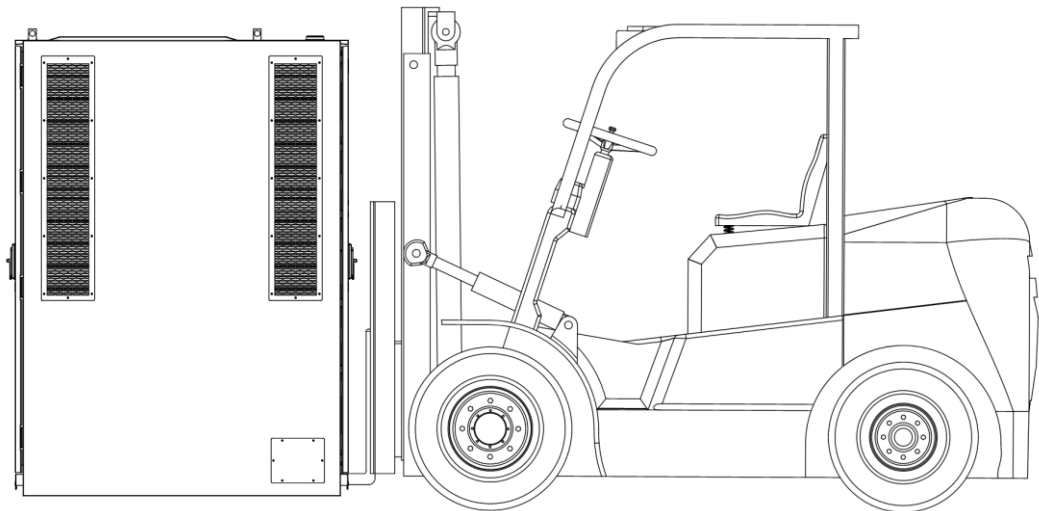

Figure I-2 Forklift Transport

Safety Instructions for Ladder Use

- Using straight ladders is prohibited.
- Before using a ladder, ensure it is in good condition and the load capacity meets the requirements. Overloading is strictly prohibited.
- Use wooden or fiberglass ladders when working overhead where electricity may be involved.
- When working overhead, it is preferable to use platform ladders with guardrails, where all four feet are securely fixed and the ladder is held by one person.

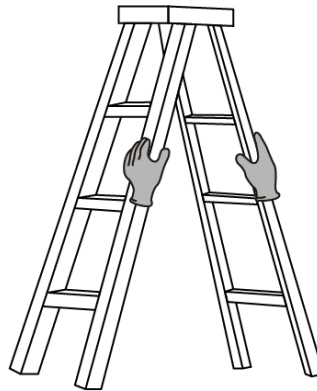

Figure 1-3 Holding Ladder

- For herringbone ladders, the rope must be secured and a person must hold the ladder during use.
- When climbing a ladder, please pay attention to the following actions to reduce danger and ensure safety.

CAUTION

- Maintain a stable body posture.
- Stand on the ladder without exceeding the 4th rung from the top.
- Ensure your center of gravity remains within the ladder frame.

Equipment Exterior Drilling Safety

- Before drilling, carefully select the drilling location to avoid short circuits or other adverse effects.
- Wear safety goggles, gloves and other personal protective equipment when drilling.
- Effectively shield the equipment during drilling to prevent ingress of debris, and clean and remove debris promptly afterward.

Safety Instructions for Handling Heavy Objects

- When handling heavy objects, arrange for the number of people recommended in the diagram to ensure collaborative operation and load sharing.

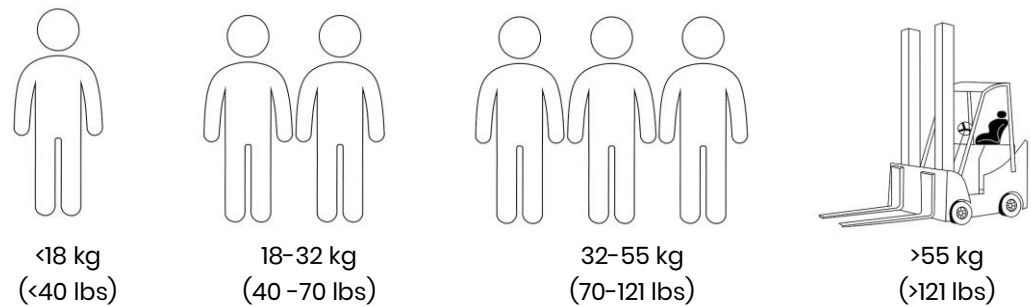

Figure 1- 4 Installation Personnel Requirements

- Wear protective gloves, anti-smash anti-puncture safety shoes and other personal protective equipment when handling the equipment by hand.
- Protect the equipment from surface scratches or damage to internal components/cables during handling.
- For forklift handling, ensure the forks are centered under the load to prevent tipping. Secure the equipment to the forklift with ropes before moving, and assign a dedicated person to monitor during movement.
- Move the equipment carefully to avoid collisions or falls.

1.7 Maintenance



Before removing any component from the cabinet, verify that all other components are securely fastened.

- A minimum of two people is required on site during ESS maintenance.
- During equipment maintenance, always use insulating materials to cover nearby live components.
- Do not open the cabinet door in severe weather conditions such as rain, snow, lightning, sandstorms, or heavy fog.
- Never allow objects (such as fingers, components, screws, or tools) to come into contact with a running fan before it is powered off or stops rotating.
- Do not power on the equipment before troubleshooting.
- During live system patrol inspections, observe hazard warnings on the equipment and avoid standing near the cabinet door.
- After shutting down the equipment other than the battery packs, wait 15 min to ensure complete de-energization before proceeding with any operation on the equipment.
- A "Do Not Close" warning sign must be displayed on any Button that is turn off for maintenance.
- After replacing power components or changing wiring in the ESS, manually initiate wiring detection and topology identification to prevent system malfunctions.
- Lock the cabinet door, secure the safety cable, and keep the key in a safe location immediately after completing maintenance and replacement.

1.8 Emergency Protocol

In the event of an incident, including but not limited to those listed below, immediately take appropriate measures to ensure the safety of all personnel on site, and contact Weiheng's service engineers.

In Case of Fire



Recommendations for on-site operation and maintenance personnel:

1. In case of fire, evacuate the building or equipment area and activate the fire alarm bell. Call the fire department and provide them with relevant product information, including but not limited to battery pack type, ESS capacity, and battery pack distribution.
2. Never re-enter the burning building or equipment area, or open the ESS door. Isolate and monitor the site, and restrict access to unauthorized personnel.
3. After contacting the fire department, remotely shut down the system while prioritizing your own safety.
4. Upon the arrival of professional firefighters, provide them with relevant product information, including but not limited to battery pack type, ESS capacity, battery pack distribution, and user manual.
5. Once professional firefighters confirm the fire is extinguished, allow qualified personnel to handle the situation according to local regulations. Do not open the ESS door without authorization.
6. Post-disaster product maintenance: Contact Weiheng's service engineers for evaluation.

Recommendations for fire professionals:

1. Review the product information provided by operation and maintenance personnel, including but not limited to battery pack type, ESS capacity, battery pack distribution, and the user manual.
 2. Do not open the ESS door if the internal safety of the system cannot be guaranteed.
 3. Please follow local fire regulations for fire extinguishing operations.
-

2 Product Introduction

2.1 Model Description

Product Model Description:

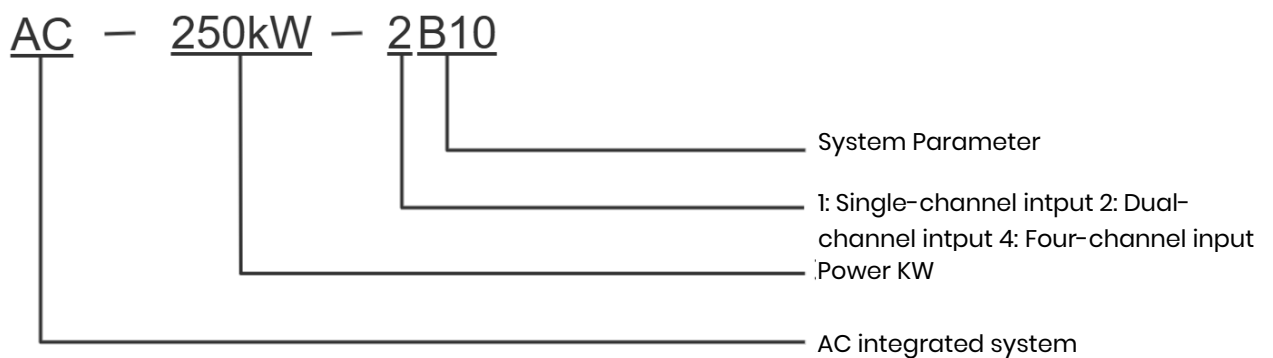

This document primarily focuses on the following product models:

- AC - 250kW - 1B10
- AC - 250kW - 2B10
- AC - 250kW - 4B10
- AC - 187kW - 1B10
- AC - 125kW - 1B10
- AC - 125kW - 2B10
- AC - 62.5kW - 1B10

2.2 Functions and Features

Function

The AC Cabinet series AC cabinet achieves streamlined integration of a modular power conversion system (PCS), local energy management monitoring, power distribution, and environmental control systems. The modular PCS simplifies maintenance and capacity expansion, while the front maintenance design minimizes space requirements for footprint and maintenance access. With these unique features, the AC cabinet ensures high safety and reliability, enabling rapid deployment and cost-effective operation with high energy efficiency and intelligent management capabilities. The operating strategy for its typical applications are described below:

Grid-connected mode: The AC cabinet is connected to the battery cabinet, and the PCS power module converts DC power to AC power and feeds it into the grid, which can achieve fast frequency response (FFR) and frequency control reserve (FCR).

Features

The AC Cabinet series AC cabinet incorporates advanced digital control technology and proprietary energy management system (EMS) to optimize control performance and improve system reliability. It offers high adaptability to various application scenarios with the following functions and features:

- **Real-time status monitoring and fault recording, enabling fault warning and location;**
- **Highly integrated structure for easy transport, operation and maintenance;**
- **Fully pre-assembled, eliminating the need to install battery modules on site;**
- **Waterproof model for outdoor applications, accommodating the needs of various installation sites;**
- **Modular design for parallel operation and ease of system expansion;**
- **Enables grid dispatching and primary frequency/voltage regulation;**

2.3. Appearance

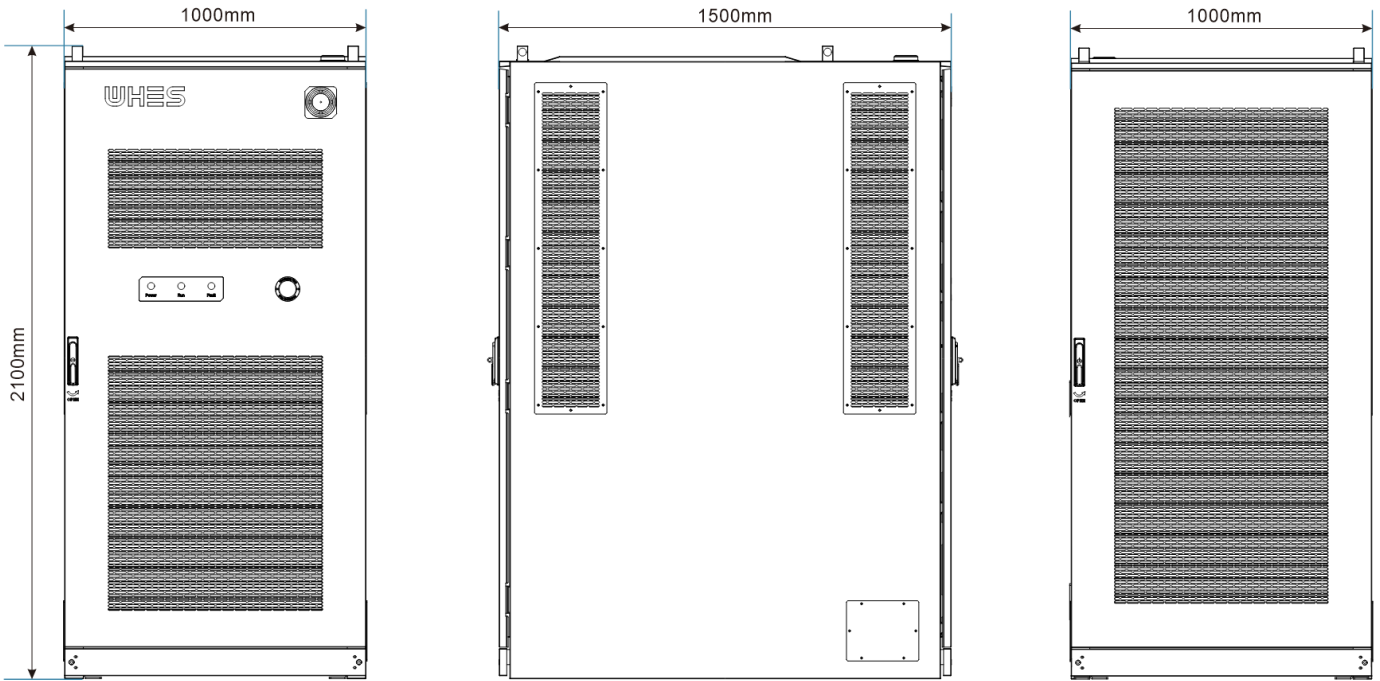

Figure 2-1 Appearance and Dimensions

NOTE

The foundation must be provided in accordance with the design drawings of the construction site. Relevant drawings can be obtained by contacting the after-sales personnel of our company.

2.4 Components

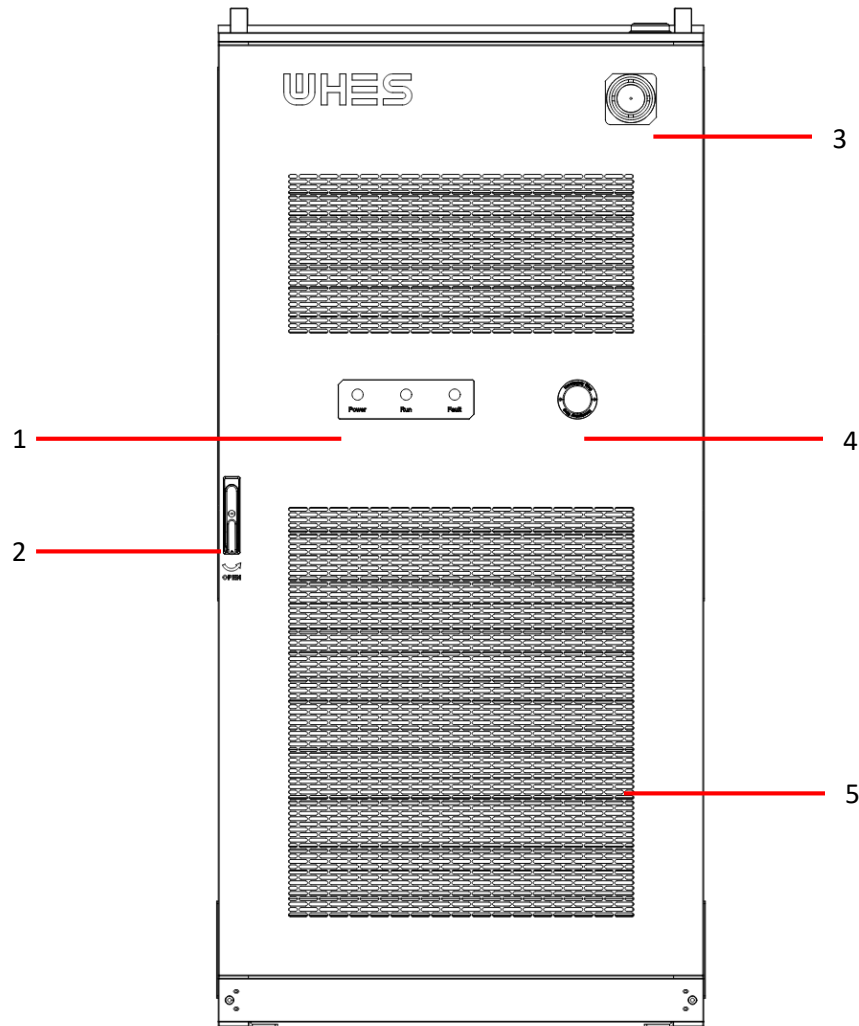

Figure 2-2 Components (Door Closed)

Table 2-1 Component Configuration

No.	Name	Quantity	Description
1	Indicator	3	Power: White, power indicator Run: Green, run indicator Fault: Red, fault indicator
2	Door lock	1	Turn the handle to open the cabinet door.
3	Audible and Visual Alarm	1	Provide audible and visual warnings for hazards to alert users in a timely manner.
4	Emergency-stop Button	1	Press the button to stop the system in the event of an abnormal equipment condition.
5	Thermovent	2	Wind inlets and outlets

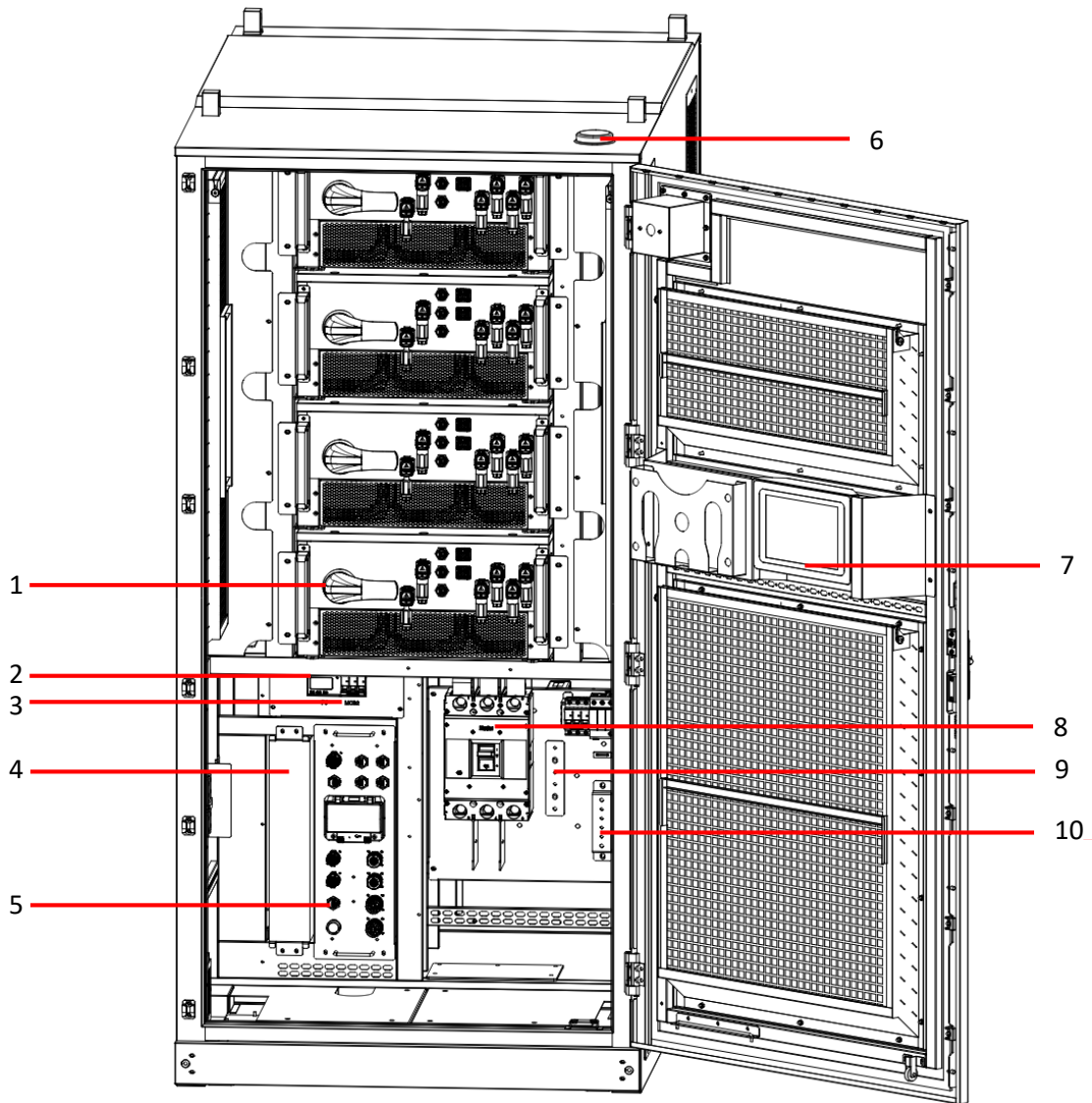

Figure 2-3 Components (Door Open)

Table 2-2 Component Configuration 2

No.	Module Description	Quantity	Description
1	PCS	4	A 62.5KW power module, enabling power conversion and management to optimize the ESS performance
2	Meter	1	Equipment revenue metering device
3	Breaker (MCB2)	1	Meter Breaker
4	UPS	1	Provide stable auxiliary power output.
5	Integrated Distribution Box	1	Integrated with EMS, BMS, data exchange and power distribution functions.
6	Antenna	1	Reserved installation position for antenna
7	Touch Screen	1	Local control panel, connected to PANGU LITE.

8	Circuit Breaker (QF)	1	Grid input line connection position.
9	N busbar	1	N busbar.
10	Grounding busbar	1	Grounding busbar.

2.4.1 Integrated Distribution Box

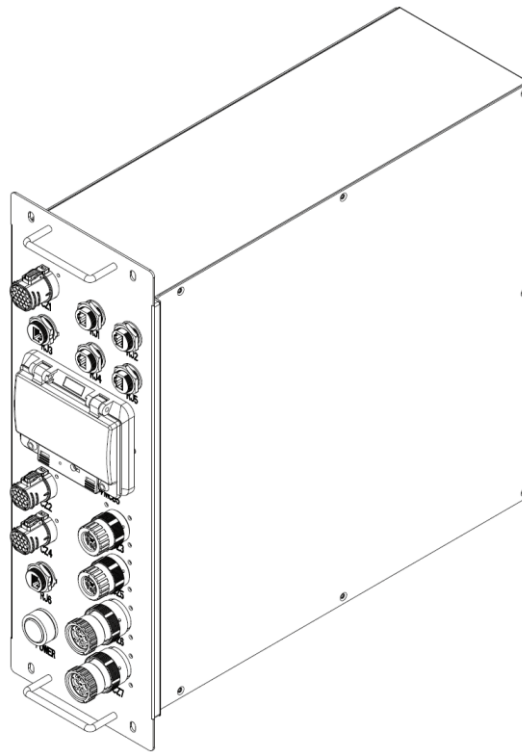

Figure 2-6 Integrated Distribution Box – Appearance

Module Description: This integrated distribution box simplifies the design and installation of the ESS by combining EMS and communication devices into a single module, significantly reducing the number of required components and ensuring easier maintenance. The integrated design not only saves space and cost, but also improves the stability and reliability of the system. It minimizes the risk of potential failures and enhances equipment durability and operational efficiency. In addition, the unified management and maintenance interface facilitates easier operation and maintenance, offers flexible scalability, and further optimizes overall system performance and management efficiency.

Features:

1. **Energy management and optimization:** Regulate battery charging and discharging, and optimize ESS efficiency.
2. **Real-time data monitoring and alarms:** Monitor system status and provide timely error warnings.
3. **Safety protection mechanism:** Integrated with overcurrent, overvoltage, overtemperature and other protection functions to prevent system failure.
4. **Remote control and maintenance:** Support remote monitoring, operation, and troubleshooting to improve maintenance efficiency.
5. **Temperature control management:** Use an integrated temperature control system (e.g. a chiller) to ensure optimal operating temperatures for the equipment.
6. **Battery health management:** Enable real-time monitoring of battery health, avoid excessive charging and discharging, and improve battery efficiency.

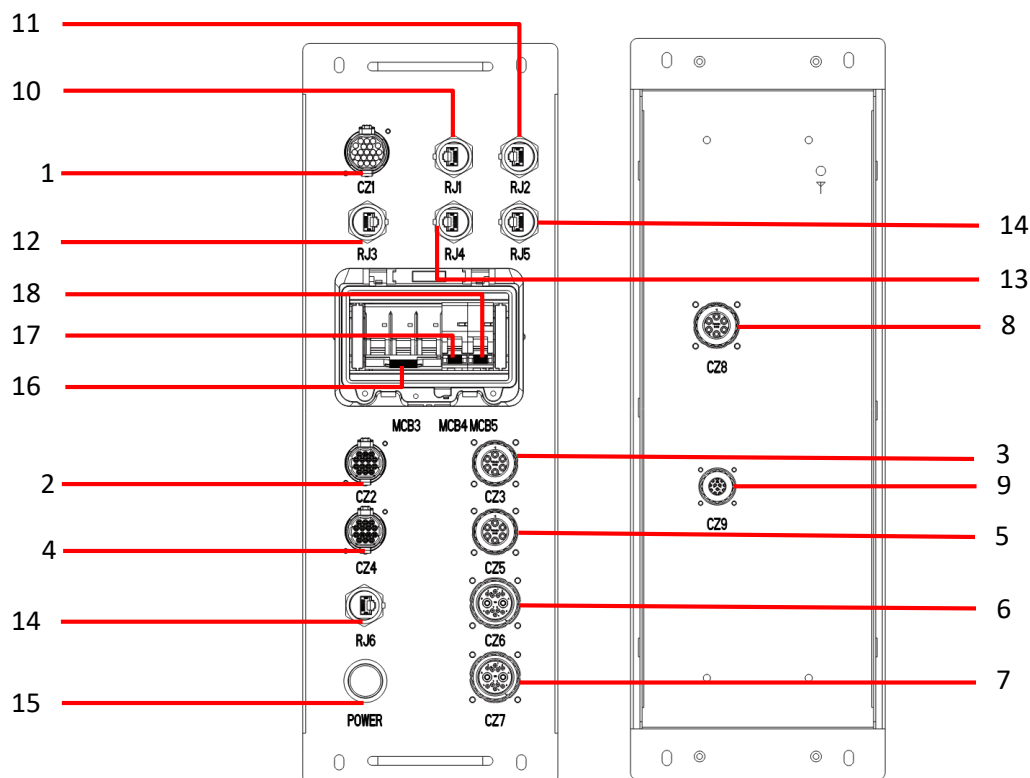

Figure 2-4 Front and rear panel display

Table 2-3 Component Configuration 3

Number	Plug	Quantity	Description
1	CZ1	1	Communication between the AC Cabinet and the integrated distribution box.
2	CZ2	1	Communication with Battery Cabinet 1#.
3	CZ3	1	Battery Cabinet #1 water cooling, HV box power supply.
4	CZ4	1	Communication with Battery Cabinet 2#.
5	CZ5	1	Battery Cabinet #2 water cooling, HV box power supply.
6	CZ6	1	Battery Cabinet 1# auxiliary power supply, dehumidifier power supply, etc.
7	CZ7	1	Battery Cabinet 2# auxiliary power supply, dehumidifier power supply, etc.
8	CZ8	1	Integrated distribution box main power supply.
9	CZ9	1	Integrated distribution box LV power supply.
10	RJ1	1	Communication with the local operation panel.
11	RJ2	1	Internal expansion network interface.
12	RJ3	1	The third ems network access port network access port.
13	RJ4	1	the converter grid security management
14	RJ5- RJ6	2	External expansion network interface.
15	POWER	1	EMS Power Indicator
16	MCB3	1	Distribution cabinet main Breaker.
17	MCB4	1	UPS input Breaker.
18	MCB5	1	HV box main power Breaker.

2.4.2 Converter System

2.4.2.1 PCS

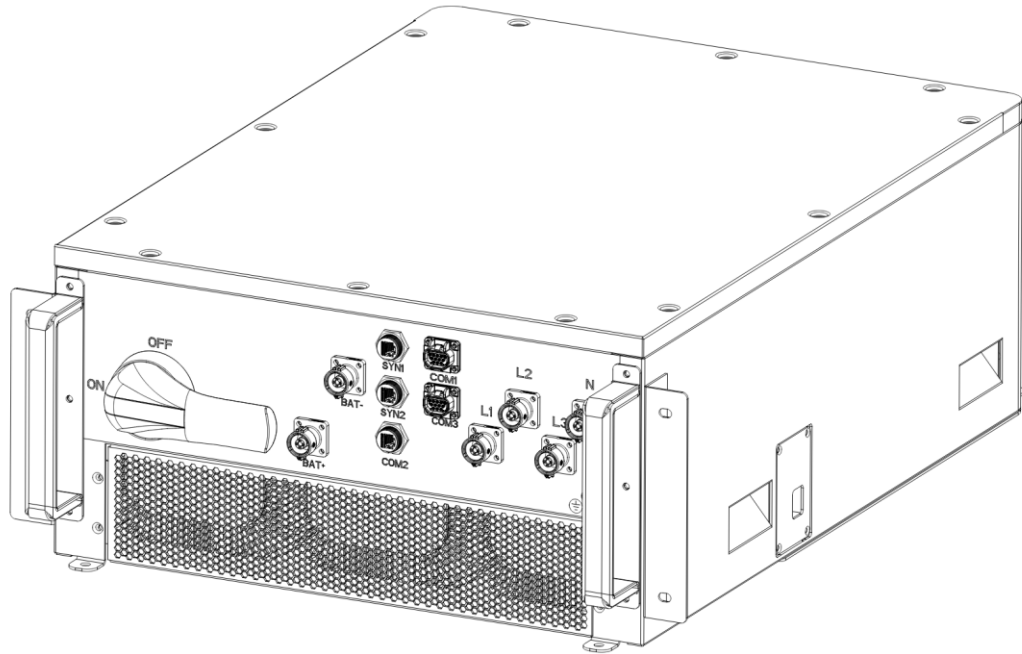

Figure 2-8 PCS Appearance

Module description:

The power conversion system (PCS) is a key component designed for bi-directional energy conversion between batteries and the grid. It ensures efficient conversion of electrical energy between AC and DC by controlling the battery charging/discharging process. The PCS features grid-connected operation capability and ensures high system reliability in different modes. Its efficient energy management and flexible operating modes allow the ESS to maintain efficient and reliable performance in various application scenarios.

Table 2-6 Technical Specifications of Converter

Model	WH-TAA603
Maximum Efficiency	98.00%
DC side- Maximum DC Voltage	950V
DC Side - DC Full Load Voltage Range	650 - 900V
DC Side - Maximum DC Current	102.3A
AC Side - Rated Active Power	62.5kW

AC Side - Maximum Apparent Power	62.5kVA
AC Side - Maximum Power	62.5kW
AC Side - Rated AC Voltage	400V
AC Side - AC Voltage Range	360V - 440Vac
AC Side - AC Power Frequency	50Hz/60Hz
AC Side - Maximum Output Current	90.21A/400V
Adjustable Power Factor Range	from -1 to +1
Total Harmonic Distortion	<3%
Grid Connection Type	Three-phase / PE
Protection - Islanding	Configured
Protection - AC Overcurrent	Configured
Protection - DC Overvoltage	Configured
Protection - Ground Fault	Configured
Protection - Residual Current Monitor (RCM)	Configured
Protection - DC Surge	Type II
Protection - AC Surge	Type III
Communication - Display	LED Indicator
Communication - Interface	Ethernet, 485, CAN
Communication - Protocol	modbus TCP/RTU
General - Dimensions (W*D*H)	543 *803*271mm
General - Weight	56kg
General - Operating Temperature Range	- 25°C ~ +60°C
General - Chiller Method	Intelligent air cooling
General - Typical Noise Emission	60dB
General - Maximum Operating Altitude (No Derating)	2000m
General - Maximum Permissible Relative Humidity (non-condensing)	0 - 100%
Connection - DC	Quick connect terminal
Connection - AC	Quick connect terminal
Protection Rating	IP65

2.4.3 Audible and Visual Alarm System

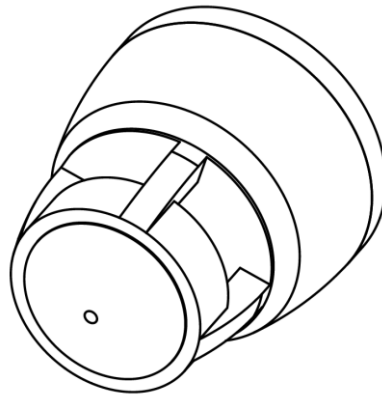

Figure 2-16 Audible and Visual Alarm - Appearance

Component Description: This audible and visual alarm can provide audible and visual alerts when triggered. It can be used with a bus-type fire alarm controller via the output module. When the fire alarm controller issues a start command, the output module activates the audible and visual alarm accordingly. Then, the audible and visual alarms emit intense visual alerts and piercing audible signals to notify on-site personnel of the fire occurrence and the necessity to implement evacuation measures, thereby preventing the fire incident from escalating.

Table 2-10 Technical Parameters

Device model	AW-D316
Operation voltage	Power supply: 24 V DC (20 V ~ 28 V)
Operating current	≤100 mA
EN54 - 23 Coverage	C - 3 - 8/W - 2.4 - 6 (see the figure below for volume coverage)
Flash Color and Frequency	White, 0.5 Hz
Light Output	According to EN54 - 23
Protection Rating	IP21C
Working temperature	-10°C ~ +55°C
Relative humidity	≤ 95% (non-condensing)
Lens/Housing Material	Flame-retardant polycarbonate/acrylonitrile-butadiene-styrene (ABS) copolymer
Dimensions	Diameter 100 mm × height 100.5 mm (including base)
Mounting Hole Spacing	45 mm ~ 70 mm
Weight	Approx. 266 g (including base)

2.5. Working Principle

2.5.1 Circuit Diagram

BEWARE

This paragraph shows the system topology diagram of the model AC - 250kW - 2B10. The current topology diagram only represents this model. If you need the system topology diagrams of other models, please contact the after - sales personnel of our company to obtain them.

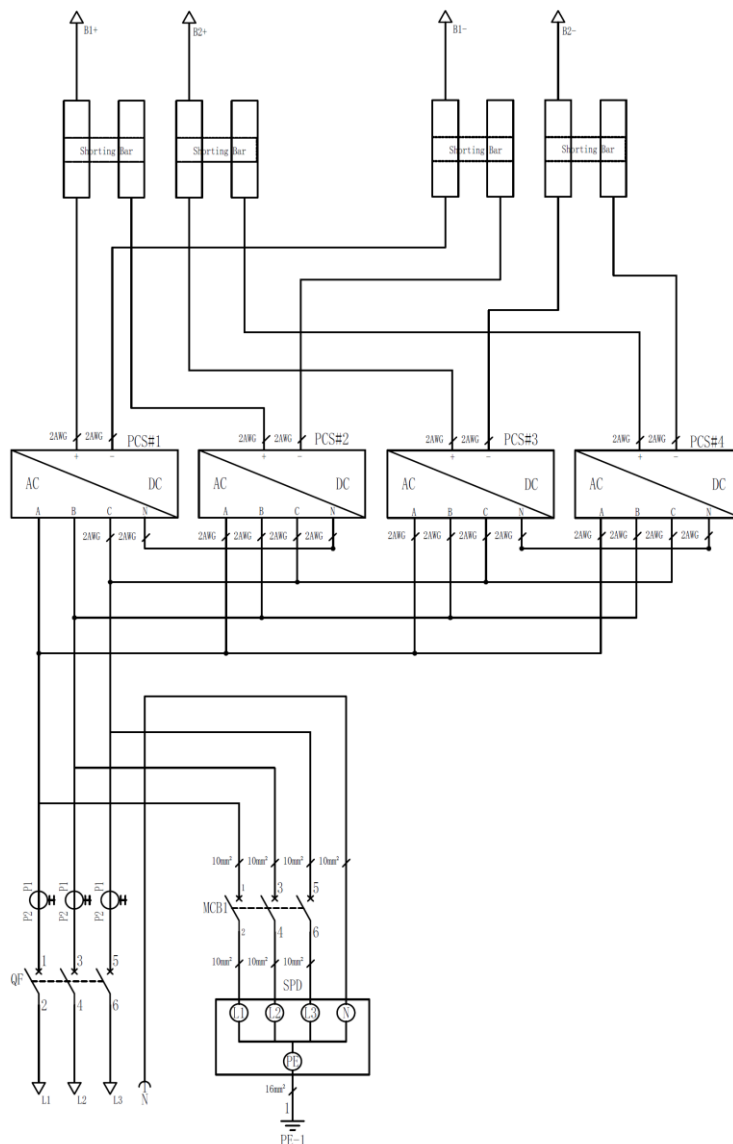

Figure 2-18 Circuit Diagram

2.5.2 Equipment Status

The AC Cabinet has 5 operating conditions: Standby, Charge, Discharge, Shutdown, Breakdowns and offline.

Table 2-11 Equipment Status

Equipment Status	Description
Standby	The AC Cabinet is powered on and connected to the grid, ready for operation at any time. However, major operations such as charging and discharging are not currently being performed.
Charge	The AC Cabinet is powered on and connected to the power grid. All components are operating normally and capable of performing charging operations, storing the electricity from the grid into the battery to provide a stable power supply for the system.
Discharge	The AC Cabinet is powered on and connected to the power grid. All components are operating normally and are capable of performing discharge operations, releasing the electricity from the battery to the power grid and providing stable power supply to the load.
Shutdown	The AC Cabinet is inactive, with the relay switch turn off and no charging or discharging activities taking place. It is currently in non-operational mode.
Breakdowns	The AC Cabinet detects an internal error, triggering a fault alarm that must be addressed before it can operate.
Offline	The AC Cabinet is turn off from the monitoring system, and no data interaction or remote control is possible.

2.5.3 System Architecture Diagram

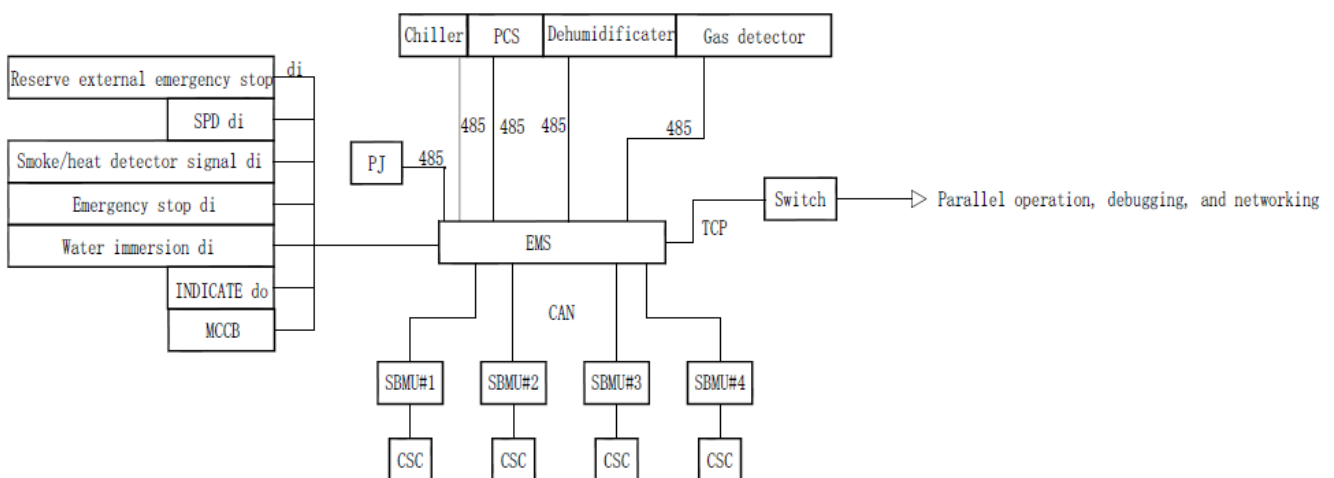

Figure 2-18 Communication topology diagram

2.6 Application Scenarios

The entire ESS station consists of AC 250kW Series Cabinets and DC Battery Cabinet Series, primarily designed for industrial and commercial applications. Specifically:

The AC Cabinet Series adopts an integrated design, incorporating the WH-TAA603 device and power distribution unit to achieve AC/DC power conversion and distribution functions. The DC Battery Cabinet Series integrates battery packs, liquid cooling systems, and fire protection systems, ensuring the safety and efficient operation of energy storage units through an all-in-one framework.

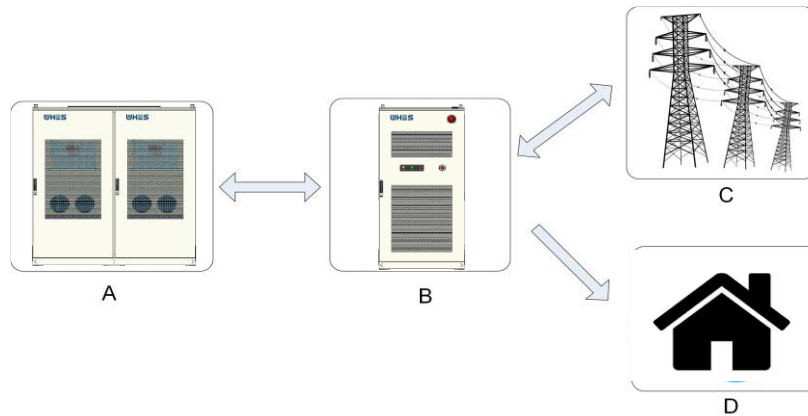

Figure 2-19 AC Coupling Application Diagram

Table 2-11 Description of Application Diagram

Identification	Equipment	Description
A	Battery Cabinet DC - 500kWh - EA10	It is used to store energy and is integrated with batteries, liquid cooling, and fire protection systems to achieve, temperature regulation, and fire safety.
B	AC Cabinet AC - 250kW - 1B10 AC - 250kW - 2B10 AC - 250kW - 4B10 AC - 187kW - 1B10 AC - 125kW - 1B10 AC - 125kW - 2B10 AC - 62.5kW - 1B10	It enables the conversion and distribution of power resources, as well as the communication and operation of power distribution and auxiliary systems.
C	Grid	/
D	Load	/

3 Site Requirements

3.1 Site Selection Requirements

BEWARE

The site shall be selected in accordance with GB 51048: Design Code for Electrochemical Power Station, NFPA 855: Standard for the Installation of Stationary Systems, and applicable local regulations.

The ESS is designed for outdoor installation. For indoor application, refer to local regulations. General site selection requirements:

- Select the installation site at a high elevation above the maximum historical water level rather than in a low-lying area.
- Maintain a minimum distance of 2 km from airports, landfills, riverbanks, and dams.
- Choose a spacious location and ensure a 10m unobstructed area around the site.
- Maintain a minimum distance of 50 m from residential areas to avoid noise pollution.
- Ensure convenient access to transportation facilities and reliable fire suppression systems.
- Provide sufficient space for current and future needs, including potential expansion throughout the life cycle.
- Choose a well-ventilated location.
- Avoid installing the ESS outdoors in saline areas where the ESS is prone to corrosion and subsequent potential fires. Saline areas refer to areas within 2 km of the coastline or affected by sea winds. Areas affected by sea winds vary based on meteorological conditions (e.g., typhoons, seasonal winds) and terrain features (e.g., dikes, hills).

 NOTE

1. If the selected site fails to meet national standards for safety clearance, it is recommended to select a new site.
2. If no suitable alternative site is available, it is recommended to install a fire wall with a minimum 3 h fire resistance rating for safety, with adequate space for equipment transport, installation and maintenance.
3. According to T/CEC 373-2020, the length and height of the firewall shall extend 1 m beyond the outer perimeter of the prefabricated cabin. According to NFPA855-2020: Standard for the Installation of Stationary Systems, an independent fire wall with a 1 h fire resistance rating allows the spacing to be reduced to 914 mm.

Site selection shall exclude locations, areas, and places that are not recommended by industry standards and regulations, including but not limited to:

- Areas with high vibration, noise, or electromagnetic interference;
- Places where dust, fumes, harmful or corrosive gases are produced or are present;
- Places where corrosive, flammable, or explosive materials are produced or stored;
- Places with existing underground facilities;
- Areas with poor geological conditions, such as rubber soil, soft soil layers, or areas prone to water accumulation and subsidence;
- Earthquake faults and areas with seismic intensity greater than 9 degrees;
- Locations susceptible to direct hazards such as mudslides, landslides, quicksand, or caves;
- Locations affected by mining subsidence (dislocation) hazards;
- Areas affected by explosion hazards;
- Areas at risk of flooding due to dam or dike failure;
- Important water source and sanitary protection zones;
- Historical and cultural relic protection zones;
- Crowded areas, high-rise buildings, and underground structures.

3.2 Forklift Requirements

- Ensure that the forklift has a load capacity of at least 2 t before using it.
- Recommended fork length: ≥ 1.8 m.

4 Equipment Installation



4.1 Pre-Installation Preparation







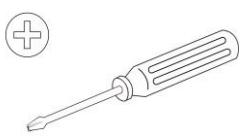

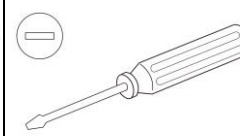
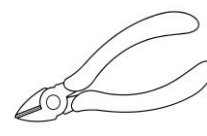

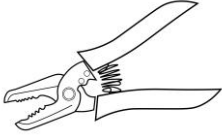
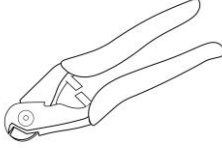

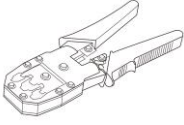
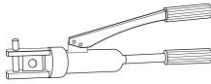
4.1.1 Tool Preparation

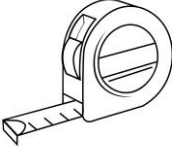

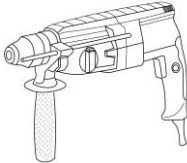

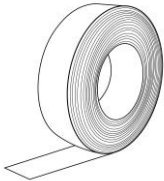
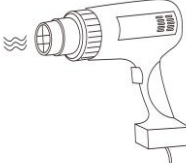
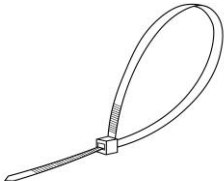
- The illustrated tools are for reference only and may differ from actual tools.
- Due to varying site conditions, this tool list may not be exhaustive. On-site installers and users are responsible for preparing unlisted tools based on actual needs.

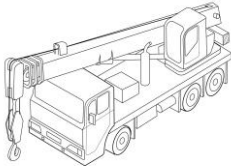
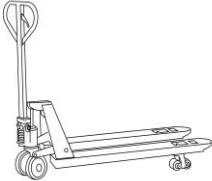

Installation Tools

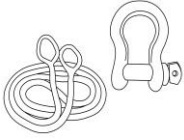
			
Phillips Insulated Torque Screwdriver	Insulated Torque Socket Wrench (including extension rod) <ul style="list-style-type: none">● Socket size: 7mm~19mm● Socket depth: ≥32mm● Socket interface compatible with torque wrench● Torque range: 1.2N·m~45N·m	Flathead Insulated Torque Screwdriver	Diagonal Pliers

 <p>Wire Strippers</p>	 <p>Wire Cutters</p>	 <p>Rubber Hammer</p>	 <p>Utility Knife</p>
 <p>Crimping Tool</p>	 <p>Hydraulic Pliers</p>	 <p>Hex Wrench: 5mm~12mm</p>	 <p>Multimeter DC Voltage range ≥1500V DC</p>
 <p>Steel Tape Measure</p>	 <p>Spirit Level</p>	 <p>Vacuum Cleaner</p>	 <p>Impact Drill</p>
 <p>Impact Drill Bit Φ16mm</p>	 <p>Heat Shrink Tubing</p>	 <p>Heat gun</p>	 <p>Cable Tie</p>
 <p>Insulated Ladder</p>	 <p>Crane</p>	 <p>Manual Forklift</p>	 <p>Forklift</p>

 <p>Lifting Rope & Shackle Rope length: ≥2200mm×4</p>	 <p>Crowbar</p>
--	--

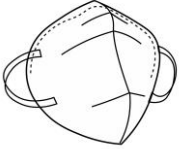
Personal Protective Equipment

 <p>Insulating gloves</p>	 <p>Protective Gloves</p>	 <p>Goggles</p>	 <p>Dust Mask</p>
 <p>Insulating shoes</p>	 <p>Reflective Vest</p>	 <p>Safety helmet</p>	 <p>Seat Belts</p>

4.1.2 Pre-Installation Inspection

Outer Packaging Inspection

Before unpacking the equipment, inspect the outer packaging for visible damage such as holes, cracks, or other signs of possible internal damage, and verify that the product model is correct. If the packaging appears abnormal or the equipment mode does not match, do not open the packaging and contact your dealer immediately.

 **NOTE**

It is recommended to remove the outer packaging within 24h before preparing to install the cabinet.

 **WARNING**

If the cabinet height exceeds 2 m, ensure appropriate safety precautions for elevated work are in place when removing the outer packaging.

Deliverable Inspection

After unpacking the equipment, inspect all deliverables to ensure they are complete and free of visible damage. If any items are missing or damaged, contact your dealer immediately.

4.2 Cable Selection

For crimping OT/DT terminals, please refer to Section A “[Crimping OT/DT Terminal](#)”.

Table 4-1 Recommended Cable Diameters

Name	AC Input Line	Neutral Input Line	Protective Ground Wire
Type	3-core outdoor copper wire	Single-core outdoor copper wire	Single-core outdoor copper wire
Single-core outdoor copper wire			
AC - 250kW Cabinet	≥185mm ² (single-core)	≥95mm ²	≥95mm ²
AC - 187kW Cabinet	≥185mm ² (single-core)	≥95mm ²	≥95mm ²
AC - 125kW Cabinet	≥120mm ² (single-core)	≥60mm ²	≥60mm ²
AC - 62.5kW Cabinet	≥50mm ² (single-core)	≥25mm ²	≥25mm ²
The cable cross-sectional areas listed in the table are the minimum required for normal system operation. Armored cables can be selected according to the site environment.			

4.3 Installing the ESS and Cables

NOTE

 **DANGER**

- Before making any electrical connections, ensure that all Breakers in the ESS are in the "OFF" position. Otherwise, the high voltage of the ESS may cause electric shock hazards.
- Measure the voltage at the contact point before touching any conductor surface or terminal, and confirm that the protective grounding conductor of the equipment or parts to be repaired is securely grounded to ensure that there is no risk of electric shock.

 **WARNING**

- Equipment damage caused by improper wiring is not covered by the equipment warranty.
- Only qualified electricians can perform electrical connection operations.
- Operators must wear personal protective equipment when making electrical connections.

 **NOTE**

The cable colors shown in all electrical connection diagrams within this section are for reference only. Cables shall be selected according to local cable standards, with yellow-green dual-color wires reserved exclusively for protective grounding).

Installation Procedure

Step 1 Remove the packaging of the cabinet.

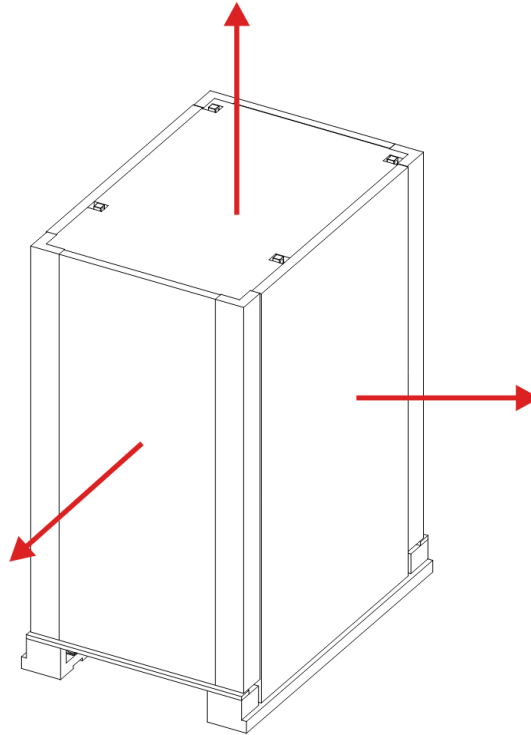

Figure 4-1 Remove the packaging

Step 2 Remove the wooden pallets.

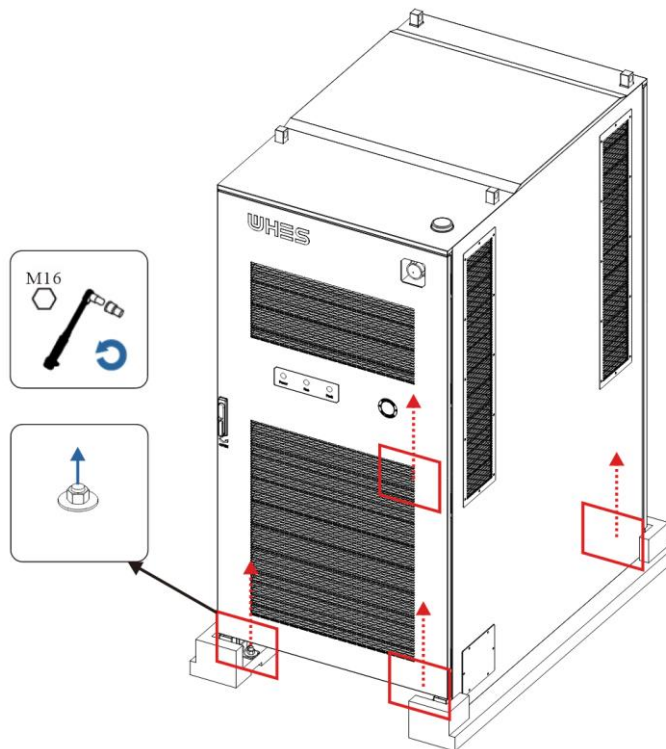

Figure 4-2 Remove the wooden pallets

Step 3 Remove the wire sealing plate.

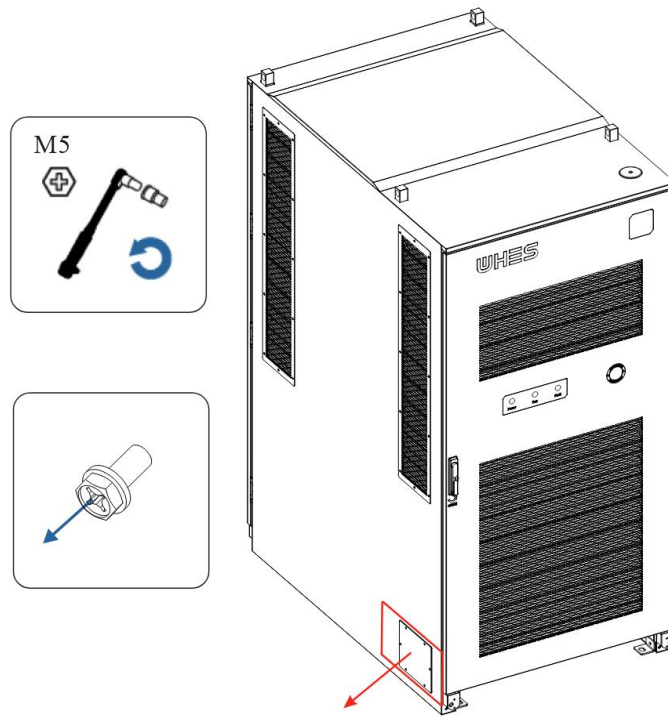

Figure 4-3 Remove the wire sealing plate

Step 4 Drill holes on the foundation and install expansion screws (M16×100, 4 pcs in total).

Use an impact drill to drill 4 holes with a diameter of 20 mm and a depth of 65-70mm on the installation foundation. The hole spacing is shown as below. Hammer in four M16×100 expansion bolts. (Exposed thread length above the platform: 30-35 mm)

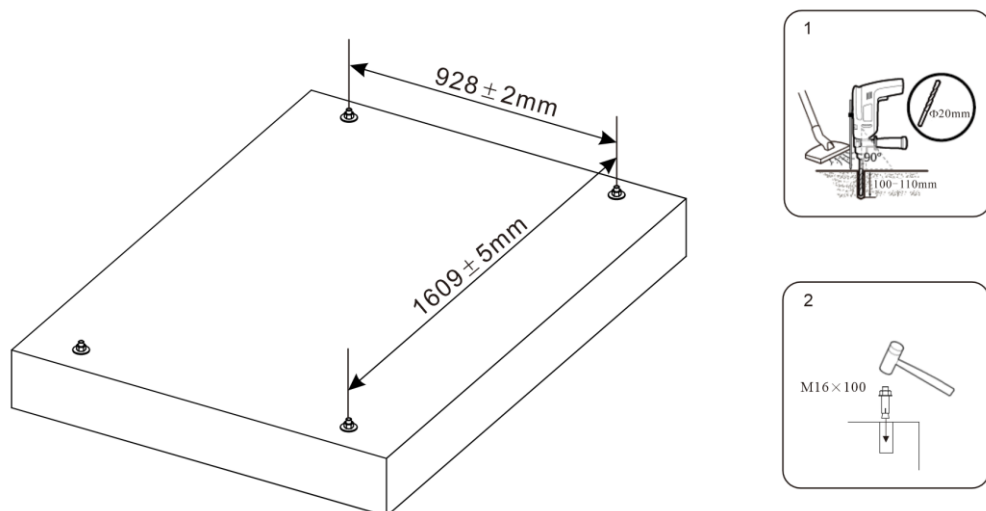

Figure 4-4 Drill holes on the foundation and install expansion bolts

Step 5 Move the cabinet to the mounting platform using a forklift or crane.

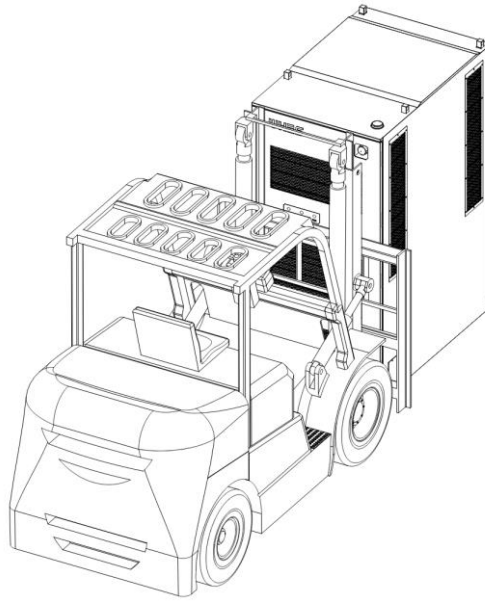

Figure 4-5 Move the ESS to the mounting platform using a forklift

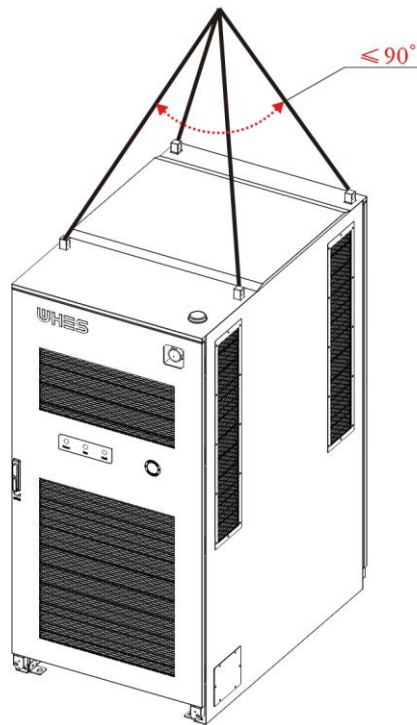

Figure 4-6 Move the cabinet to the mounting platform using a crane

i BEWARE

When using a forklift or crane to move the equipment, secure the equipment with appropriate straps based on the actual situation to prevent the risk of overturning.

Step 6 Option 1: Install the enclosure fixtures (sheet metal) and mount the system.

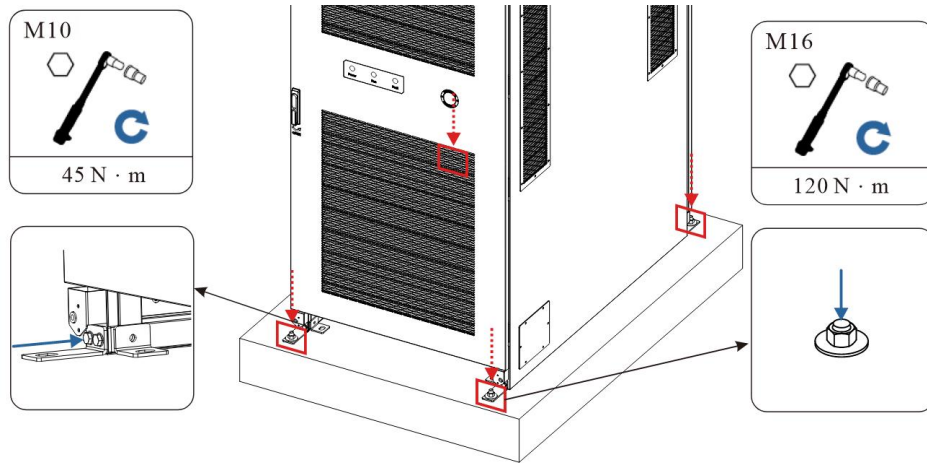

Figure 4-7 Install the enclosure fixtures (sheet metal) and mount the platform

Option 2: Welded to metal base

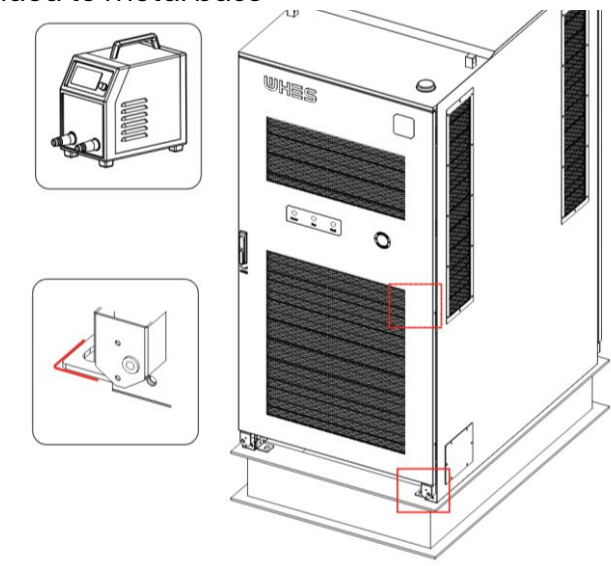

Figure 4-8 Welded to metal base

BEWARE

After welding and fixing, it is necessary to promptly apply anti-rust paint such as epoxy primer to the welded areas and their surroundings to form a protective layer. If it is in a humid or corrosive environment, anti-rust grease can be applied additionally to strengthen the protection. Regular inspections should be carried out, and if the paint layer peels off or rusts, clean the area and repaint it in time.

Step 7 Ground the enclosure.
Option 1: Weld a grounding busbar.

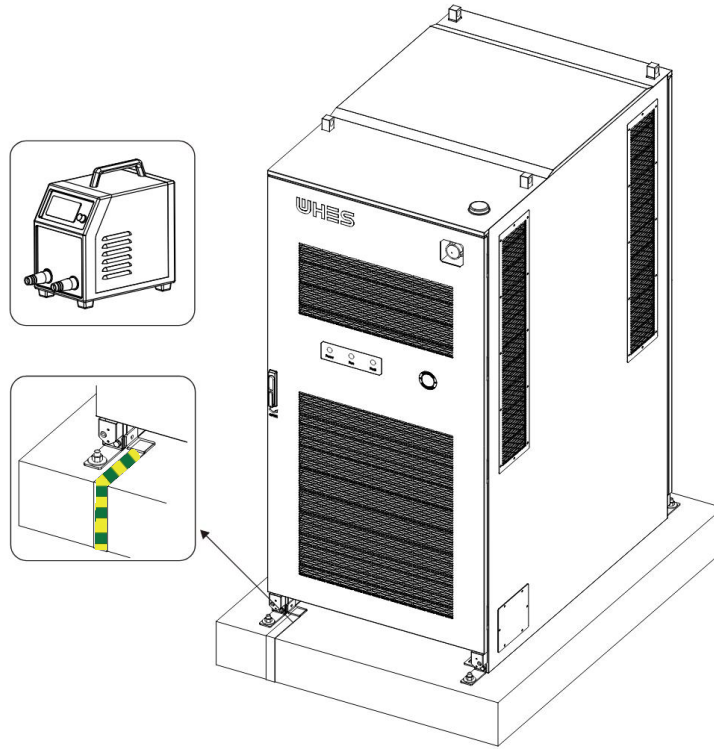

Figure 4-9 Weld a grounding busbar

Option 2: After completing Step 7, install a grounding wire

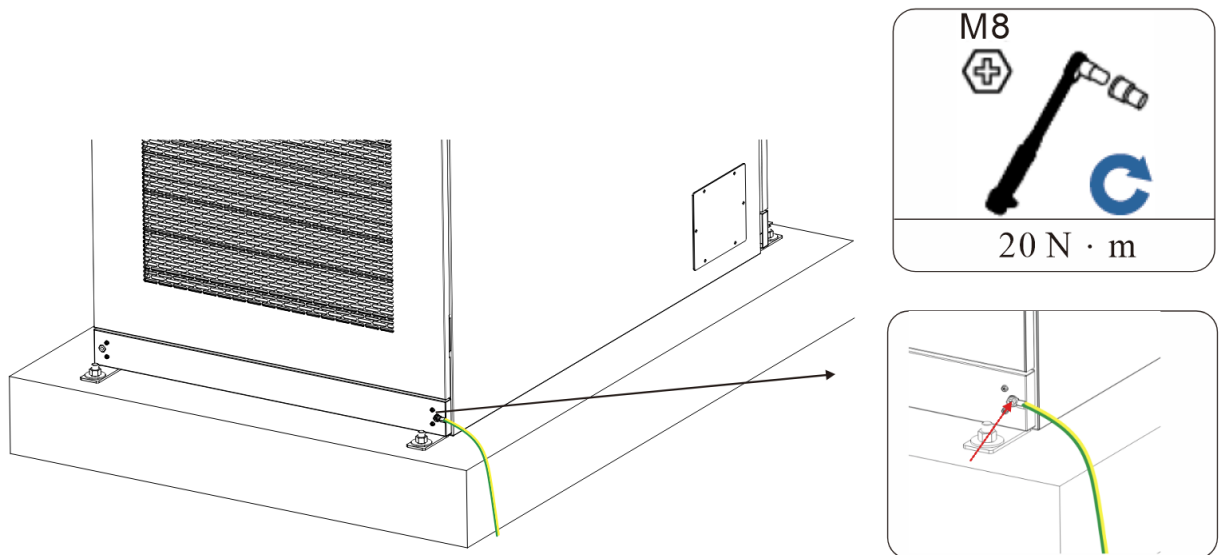

Figure 4-10 Install a grounding wire

Step 8 Install the front and rear cover plates.

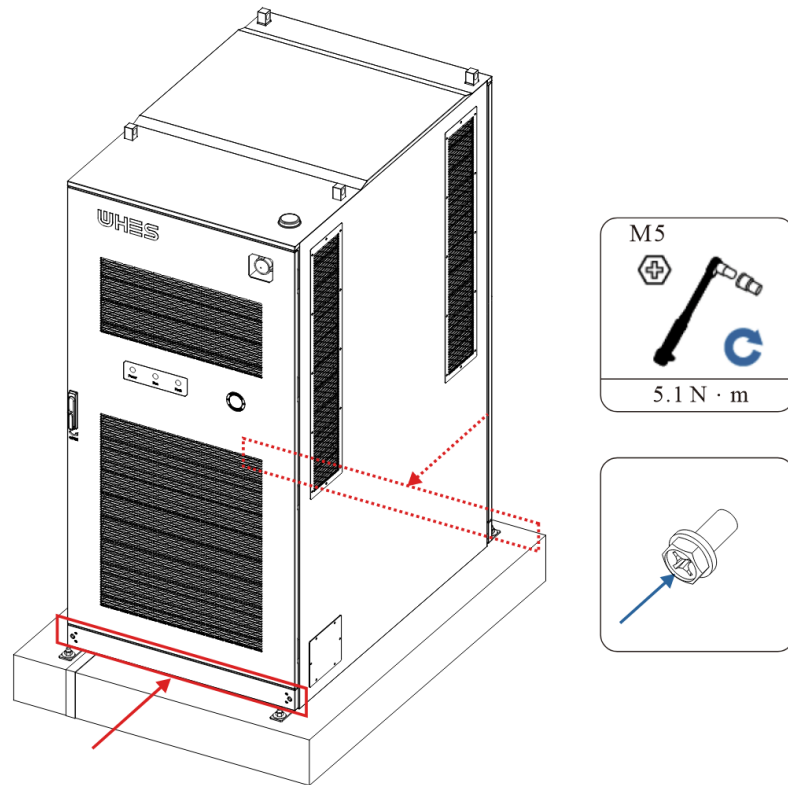

Figure 4-11 Install the front and rear cover plates

Step 9 Open the front cabinet door.

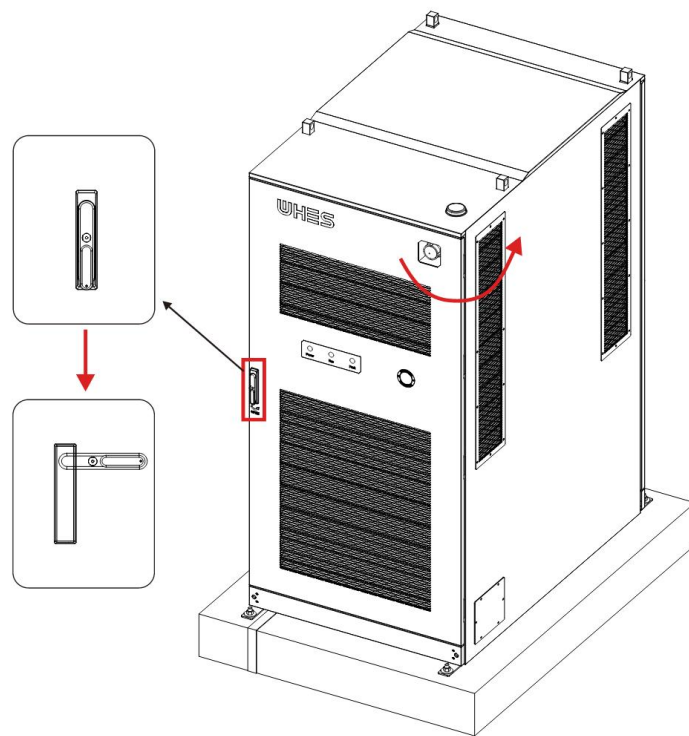

Figure 4-12 Open the front door of the battery compartment

Step 10 Remove the AC/DC protective plates.

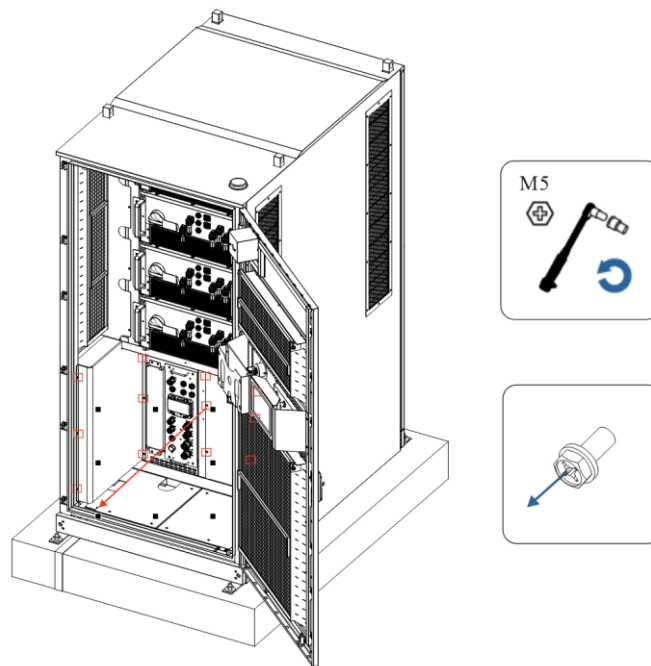

Figure 4-13 Remove the AC/DC protective plates

Step 10 Install AC cables.

BEWARE

The color codes of AC cables shown in the figure below follows the European standard. For color codes applicable in other regions, please refer to **Table 4-2: Color Codes of Three-Phase Wires**.

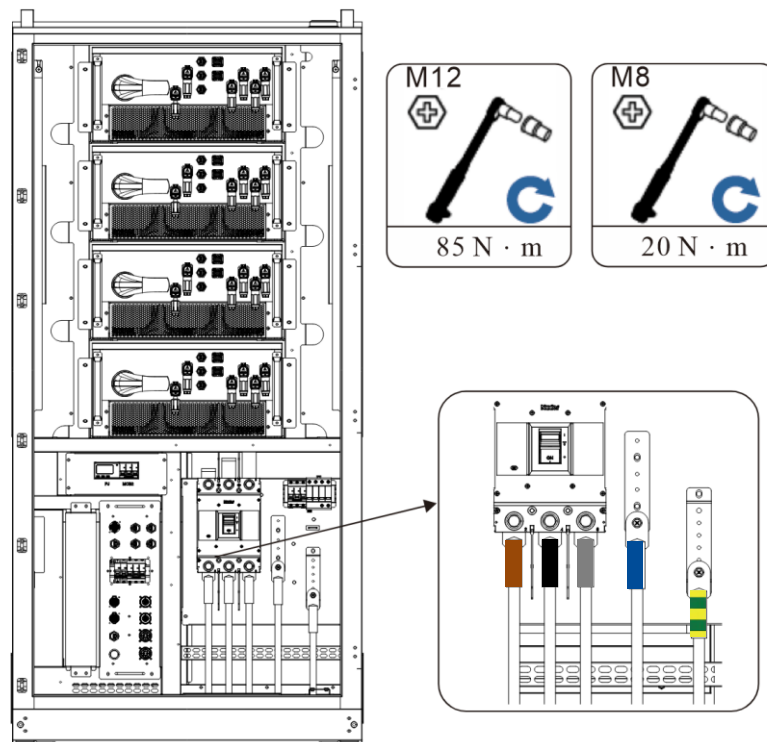

Figure 4-12 Install AC cables

Table 4-2 Color Codes of Three-Phase Wires

Region	L1	L2	L3	Neutral Wire	Ground wire	Description
China	Yellow	Green	Red	Blue	Yellow green stripes	The table outlines the three-phase wire color requirements for various countries and regions worldwide. If the colors indicated in the table differ from those at the installation site, the latter shall prevail.
USA	Black	Red	Blue	Grey	Green	
European, Germany, United Kingdom	Brown	Black	Grey	Blue	Yellow green stripes	
Malaysia	Red	Yellow	Blue	Black	Yellow green stripes	
India	Red	Yellow	Blue	Black	Green	

Step 12 Disassemble the fixing pressure plate of the protective coil (Including battery cabinet).

BEWARE

The battery cabinet model shown in the figure below is DC-500kWh. This manual does not include the complete installation procedure of the battery cabinet. For the complete installation procedure of the battery cabinet, please refer to the DC-500kWh user manual.

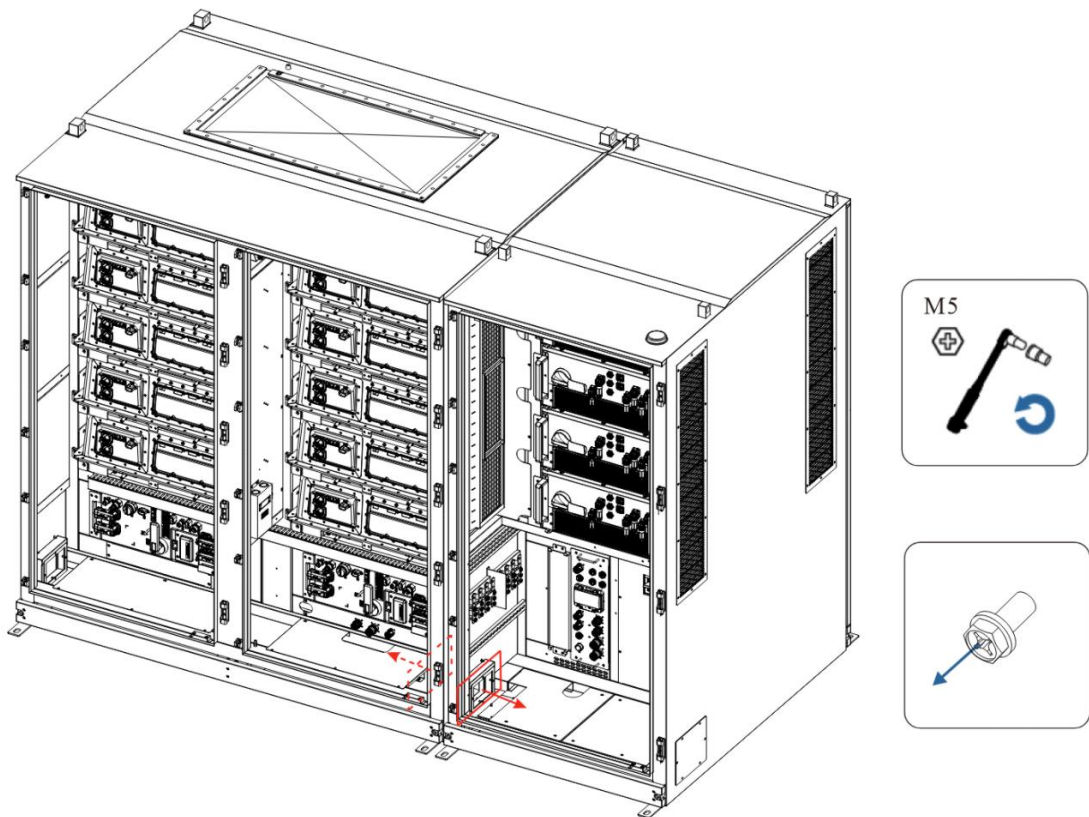
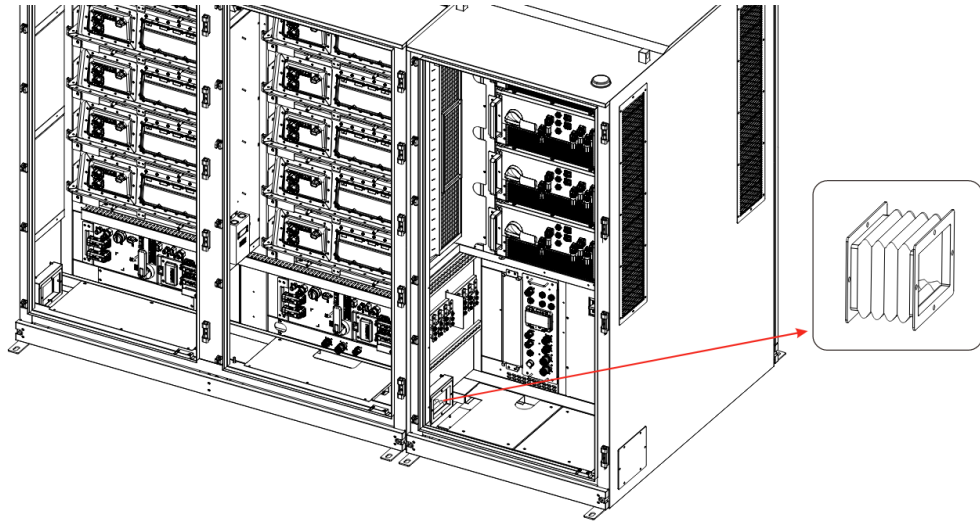

Figure 4-15 Remove the coil pressure plates

Step 13 Install the silicone coil.



■ **Figure 4-16** Install the silicone coil

Step 14 Install the fixing pressure plate of the protective coil (including battery cabinet).

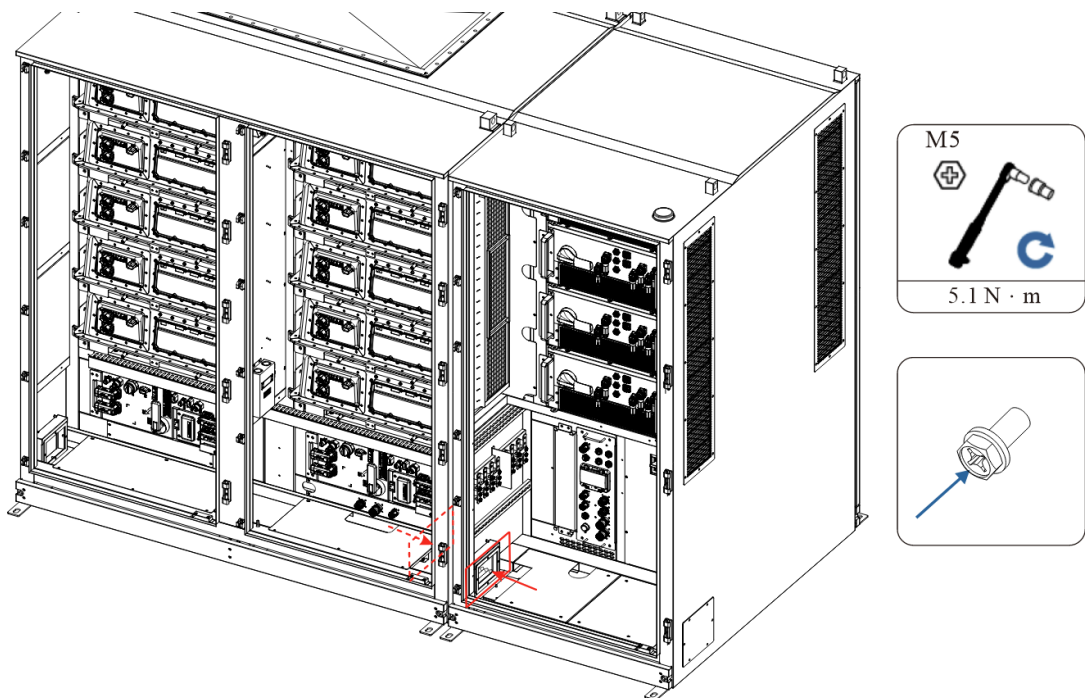

■ **Figure 4-17** Install the coil pressure plates

Step 11 Install DC cables

BEWARE

The figure below illustrates the installation method for DC cables based on the DC-500 kWh series battery cabinet. For wiring of other DC cabinet series, please consult our customer service.

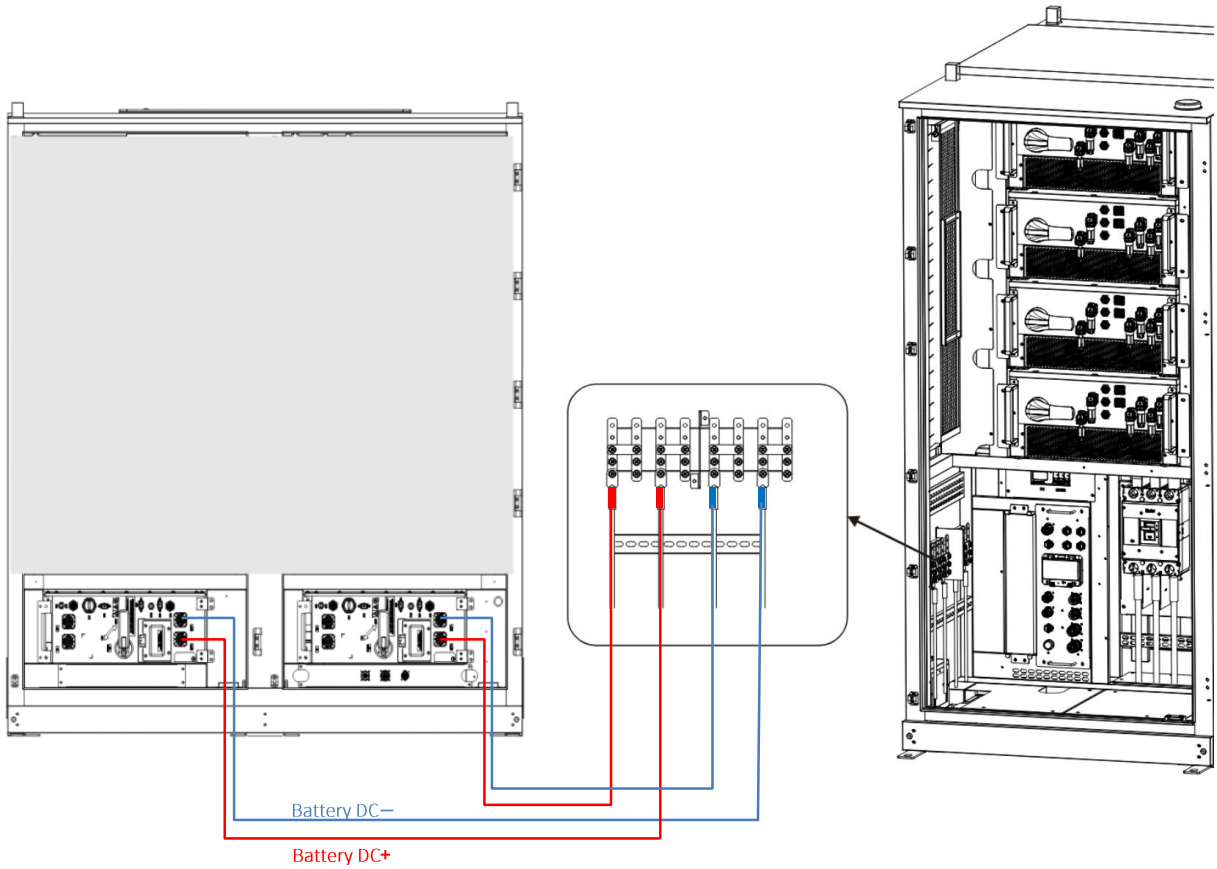

Figure 4-13 Install DC cables

Step 12 Install communication cables.

BEWARE

The figure below illustrates the installation method for communication cables based on the DC-509 kWh series battery cabinet. For wiring of other DC cabinet series, please consult our customer service.

The communication harness is included with the cabinet accessories. If the delivered harness is found to be damaged, please contact our customer service for assistance.

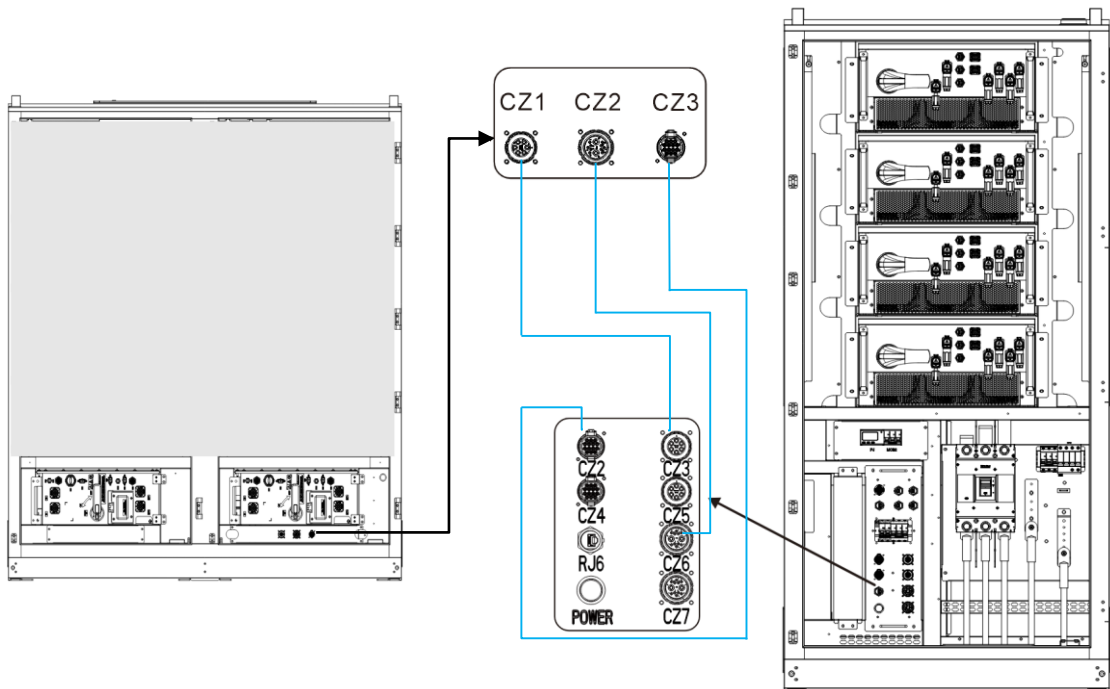

Figure 4-15 Install communication cables

Step 13 Seal the wiring hole.

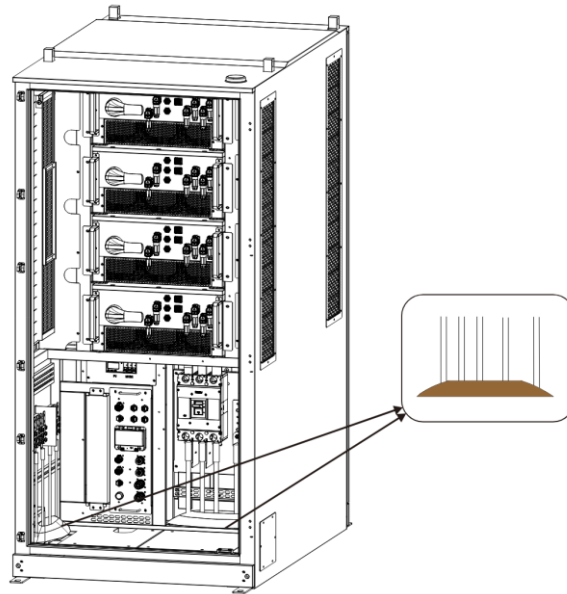

Figure 4-16 Seal the wiring hole

Step 14 Reinstall the AC/DC protective plates.

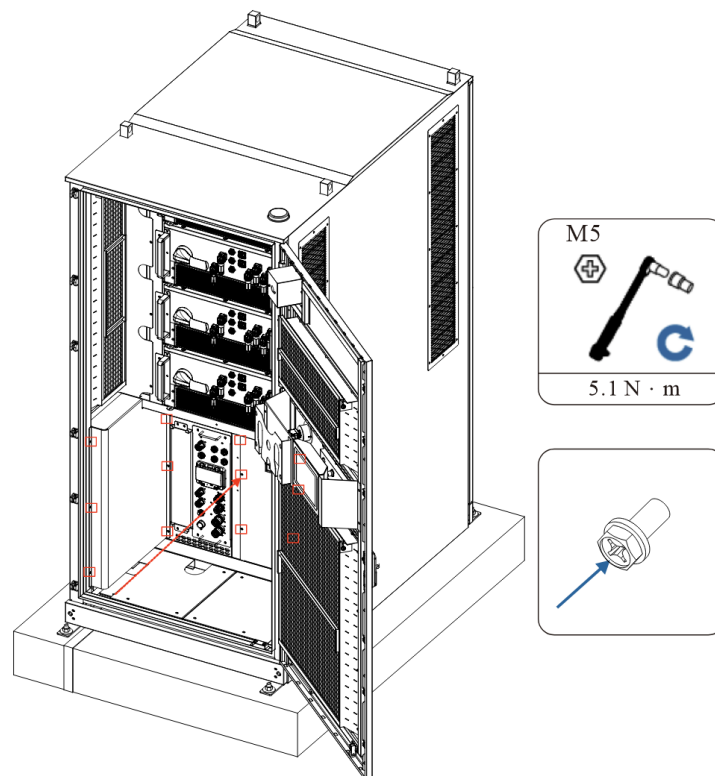

Figure 4-17 Reinstall the AC/DC protective plates

Step 15 Close the front cabinet door.

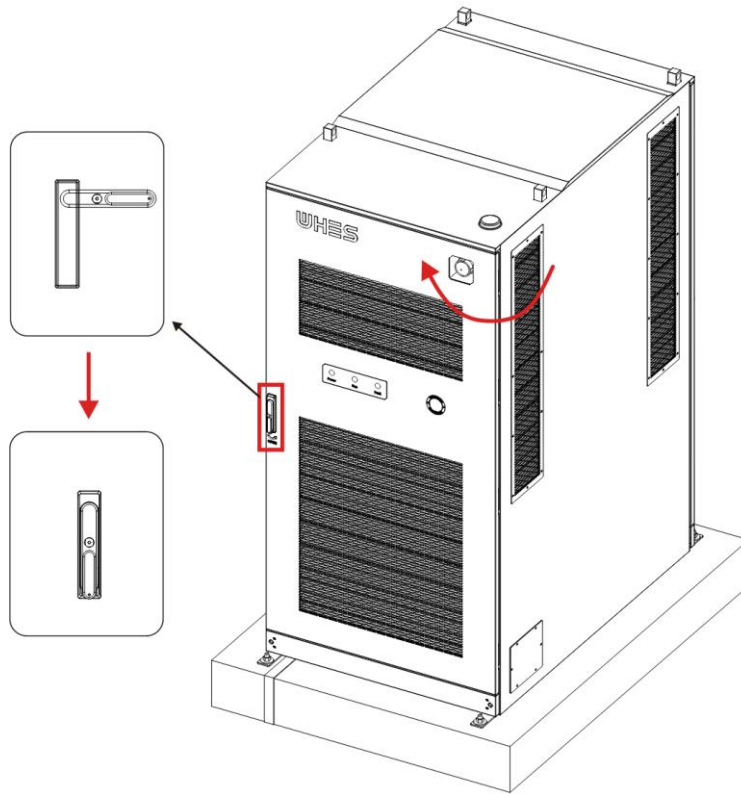

Figure 4-18 Close the front cabinet door

5 System Power-On

5.1 Pre-Power-On Inspection

No.	Inspection Item	Acceptance criteria
1	Equipment Appearance	The equipment is intact and free of visible damage, rust, or peeling paint. Repaint any areas with peeling paint.
		All labels on the equipment are clearly visible and legible. Replace damaged labels promptly.
2	Cable Appearance	Cable protective layers are well wrapped and free of visible damage.
		Cable conduits/hoses are intact.
3	Cable Connection	Cable connections are correctly positioned according to the design.
		Terminals are properly installed in accordance with specifications, and connections are secure and reliable.
		All cables are clearly identified at both ends with legible labels that are oriented in a consistent manner.
4	Cable Routing	Cables are routed by separating strong and weak power systems.
		Cabling is organized in a neat and orderly manner.
		Cable ties are trimmed flush, eliminating sharp edges or protrusions.
		Bends are properly managed with sufficient slack, without over-tensioning cables.
		All cables are routed straight and smooth inside the cabinet, avoiding crossovers.
5	Breaker	All circuit breakers in the power distribution cabinet are in the OFF position.
		All breakers in the HV box are in the OFF position. (battery cabinet)

6	Enclosure Grounding	Each enclosure has at least two securely connected grounding points with a maximum contact resistance of 0.1Ω.
7	Identification	Identification is correct, legible, and complete.
8	Sealing of Cable Openings	All cable openings are properly sealed.
9	Battery Pack	All battery pack are free of visible damage.
10	Foreign Objects	All foreign objects such as tools, and leftover installation materials are removed from the cabinet.
11	Power Distribution Area Cover Plate	The cover plates in the power distribution area are free of visible cracks, dents, scratches, breakage, or looseness.
12	Sub-Components (EMS, BMS, UPS, etc.)	All sub-components are free of visible damage.

5.2 Power-On Procedure

Table 5-1 Power-On Procedure

Step	Project	Comment
1	Close the AC input line QF.	/
2	Close the circuit breaker groups MCB2 and MCB3 in sequence.	Activate the integrated distribution box EMS module and click the GN button.
3	Close MCB4 and BCB5.	Press and hold "ON" for 10 s until a "beep" sounds, then the UPS is breakered on.
4	The battery cabinet is powered on.	Check if all equipment is powered on and pay attention to safety precautions.
<p>Note a: Before closing the auxiliary communication circuit breaker (MCB3) of the battery cabinet, ensure that the connection harness between the battery cabinet and the integrated distribution box is securely connected.</p>		

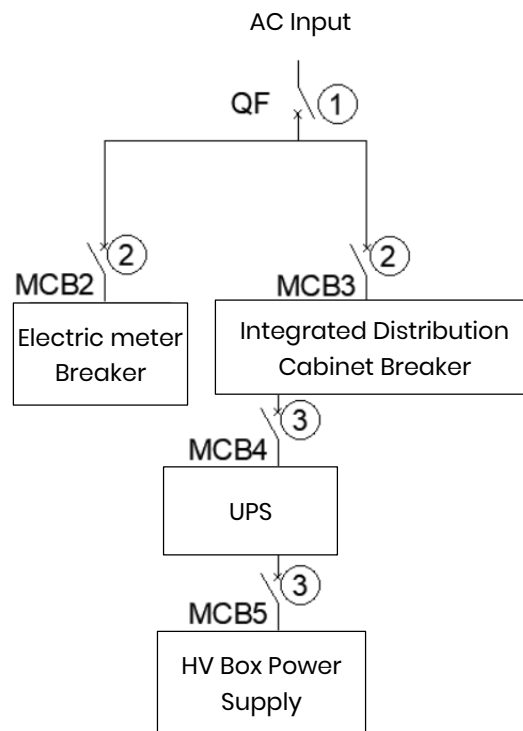

Figure 5-1 Power-On Flow Chart

6 Power-On Commissioning (PANGU-LITE)

Prerequisites

1. All on-site equipment has been fully commissioned upon arrival.
2. The system has been successfully powered on, and all alarms have been cleared.
3. Commissioning devices for startup are available on site.

6.1 Preparation and PANGU LITE Access

Procedure

As shown in the figure, use the fixed operation display on the door panel to enter the PANGU-LITE screen.

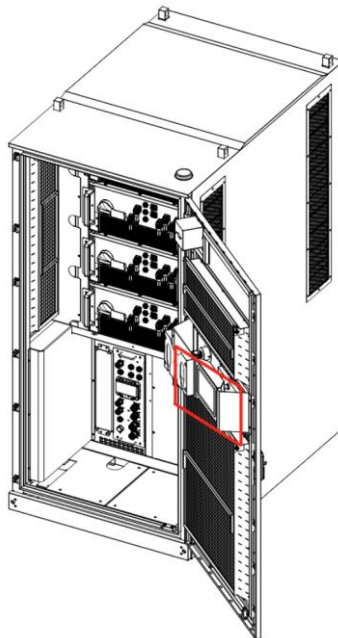

Figure 6-1 Diagram Wiring Diagram for Communication Cables

If the screen fails to appear automatically, open the browser and enter 133.144.155.10:8080/lite to access the PANGU-LITE screen.

6.2 HMI Description

Home Screen:

1. After accessing this screen, you can customize the language, time zone, display settings, and other parameters at the top right corner.
2. This screen shows the direction of energy flow in the system, as well as the real-time operating status of the PCS, battery and grid. The alarm/message system refreshes the operating status and data every 5s.
3. This flow shows the three-phase voltage and current of the grid, the power supply of the PCS, as well as the SOC, voltage and current of the battery.
4. PCS operating conditions:
 Charging: Indicate that the equipment is charging.
 Discharging: Indicate that the equipment is discharging.
 Offline: Indicate that the equipment is in an offline state.
 Standby: Indicates that the equipment is functioning normally without faults and is not in the charging or discharging process.

Inactive: Indicate that the equipment has stopped operating.

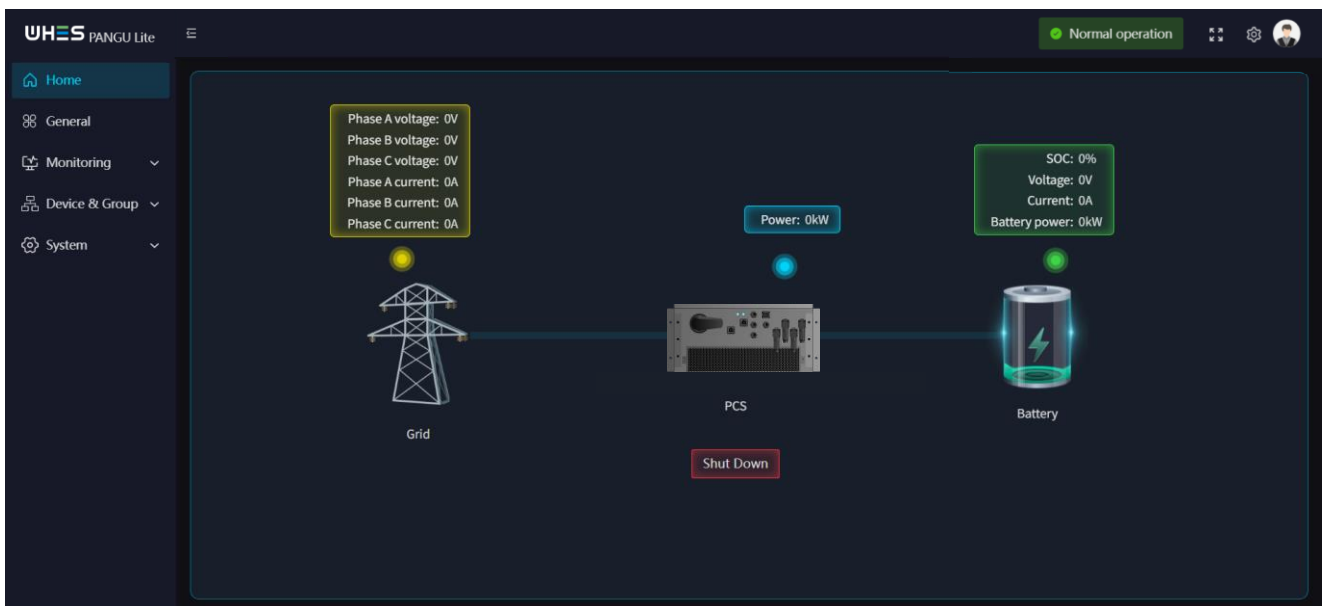

Figure 6-2 PANGU LITE – Home

Energy Storage Overview:

This screen displays basic system information, including EMS-SN, rated power, rated capacity, maximum charge power, number of PCS units, number of battery clusters, charge/discharge power, available charge/discharge capacity, SOH, and SOC.



Figure 6-3 PANGU LITE - Overview

Operation Monitoring - PCS Screen:

This screen allows real-time monitoring of DC current, DC voltage, and three-phase voltage data, and monitors all operating conditions of the PCS. It also displays operating and simulated data of the PCS, including design capacity, maximum and minimum design voltage, frequency, power factor, active power and reactive power.



Figure 6-4 Operation Monitoring - PCS Screen

Operation Monitoring – BMS Screen:

This screen displays SOC/SOH monitoring information, operating status, and detailed operating data for the battery BMS. It also displays real-time status and data for all battery clusters.

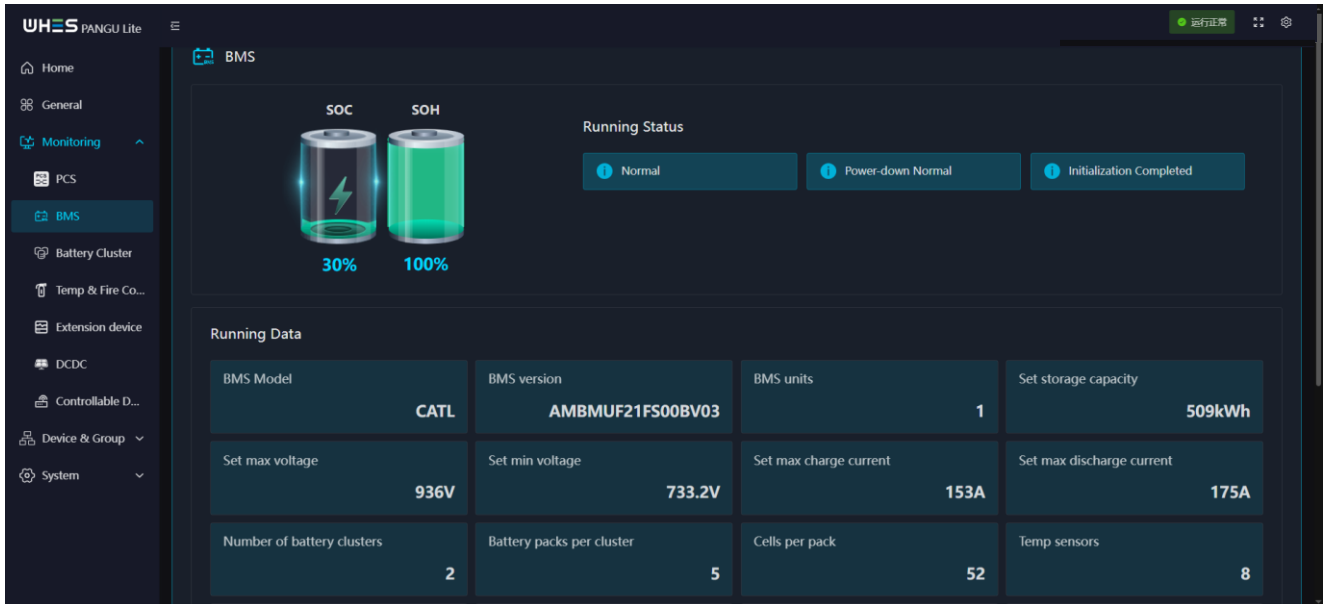

Figure 6-5 Operation Monitoring – BMS Screen

Operation Monitoring – Battery Cluster Screen:

This screen monitors the voltage and temperature of each battery in the pack, as well as all operating data for the entire battery cluster.

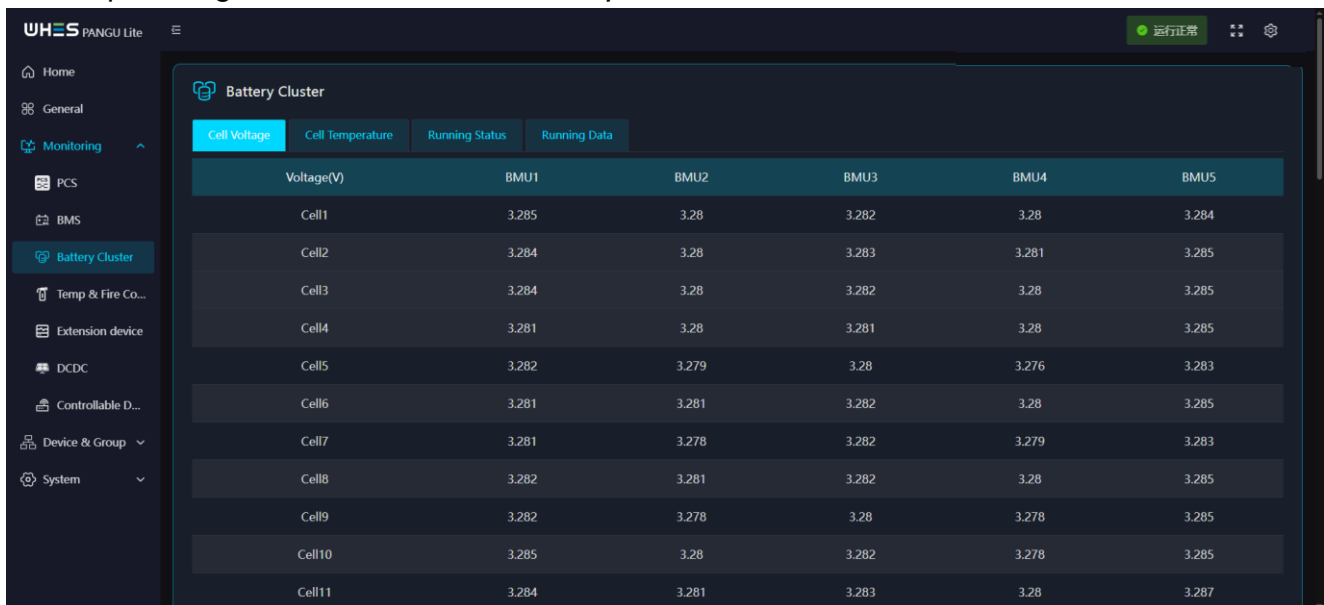

Figure 6-6 Operation Monitoring – Battery Cluster Screen

Operation Monitoring – Temperature Control & Fire Safety Screen:

This screen monitors the inlet and outlet water temperature, pressure and operating status of the water chiller system, as well as the operating status of the air conditioning and fire protection systems.

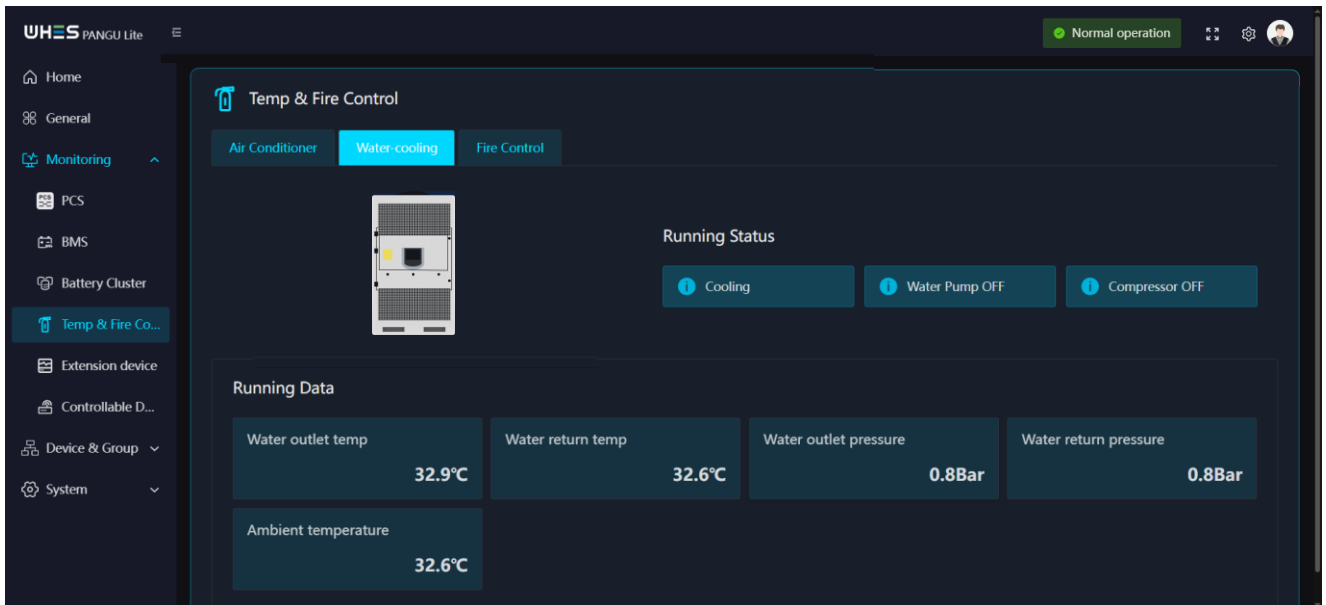

Figure 6-7 Operation Monitoring – Chiller & Fire Protection Screen

System Configuration – System Status Screen:

This screen allows you to view the system operating status and perform system control.

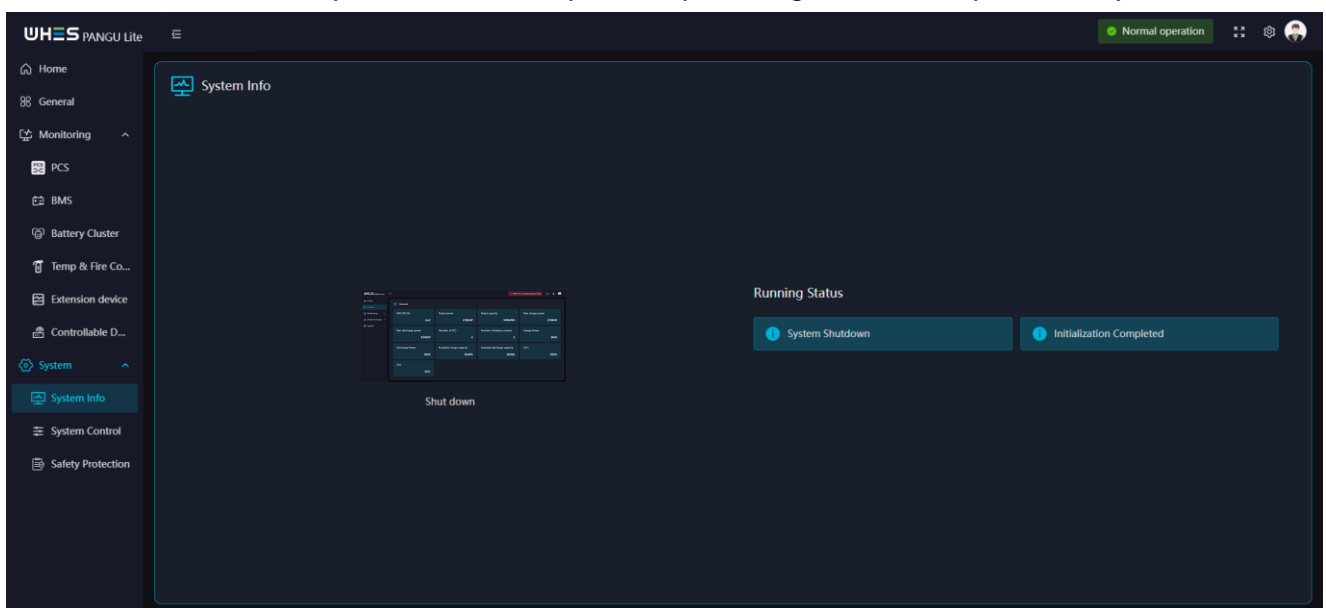

Figure 6-8 System Configuration – System Status Screen

System Configuration – System Control Screen:

This screen allows you to control the system, including the system button, reset, grid button, control mode, SOC lower discharge limit, power factor, power control, and coordination control button.

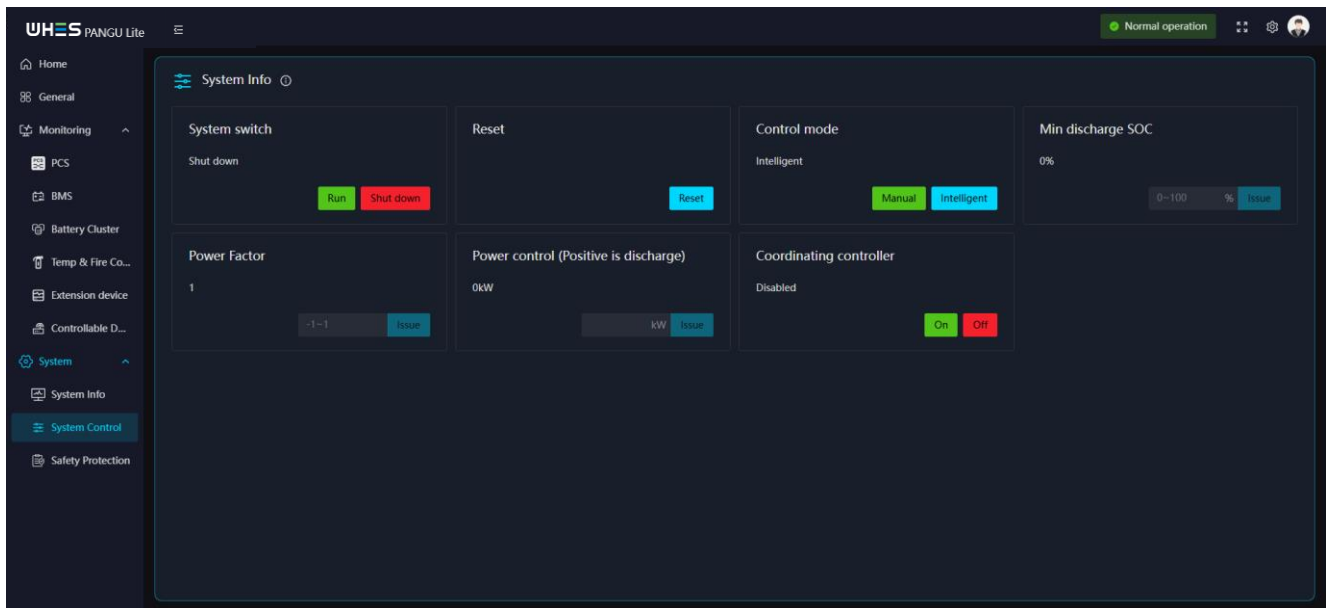

Figure 6-9 System Configuration – System Control Screen

6.3 Startup Procedure

Procedure

Step 1 Navigate to "System Configuration > System Control", click the "Start" button, and verify that the equipment status has been buttoned to on-grid mode.



Step 2 Check the "Home" screen to verify that the PCS is in standby mode.

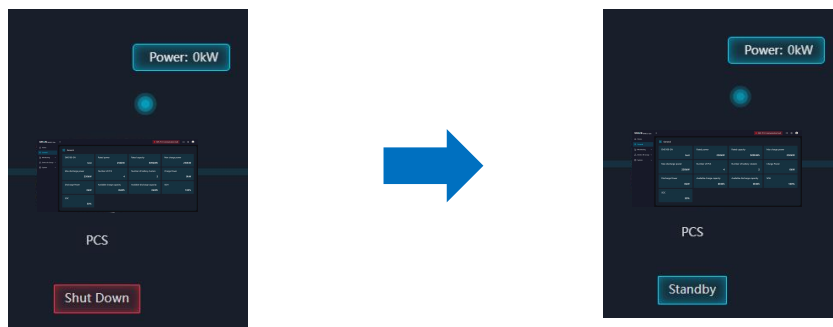

Step 3 Navigate to "System Configuration > System Control", enter -10 kW in the "Power Control" module, and click the "Apply" button.



Step 4 Check the "Home" screen to verify that the PCS is in charging mode, and view the real-time display of system operating power.

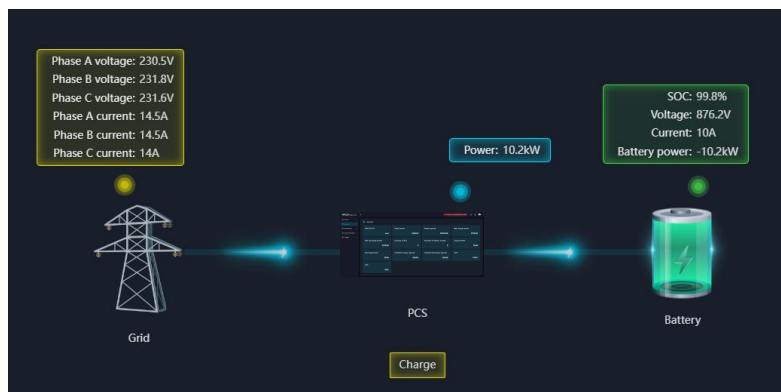

6.4 Shutdown Procedure

Operation Procedures

Step 1: Navigate to "System Configuration > System Control", enter 0 kW in the "Power Control" module, and click the "Apply" button.

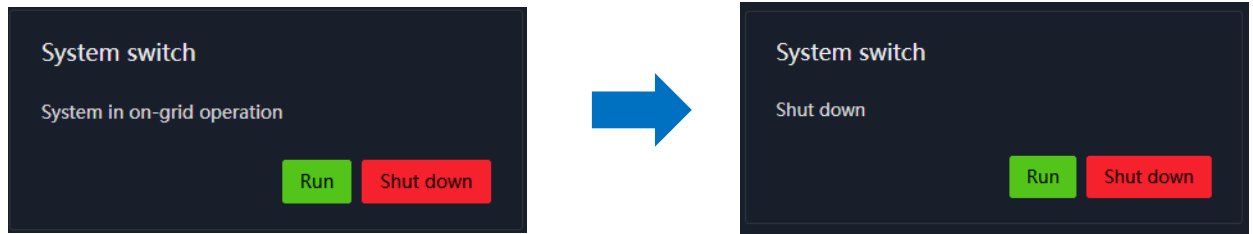

Step 2: Check the "Home" screen to verify that the PCS is in standby mode.

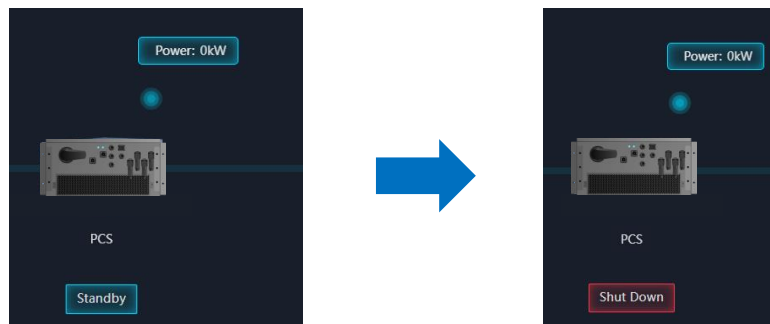

Step 3: Navigate to "System Configuration > System Control", click the "Stop" button, and verify that the equipment status has been buttoned to inactive mode.

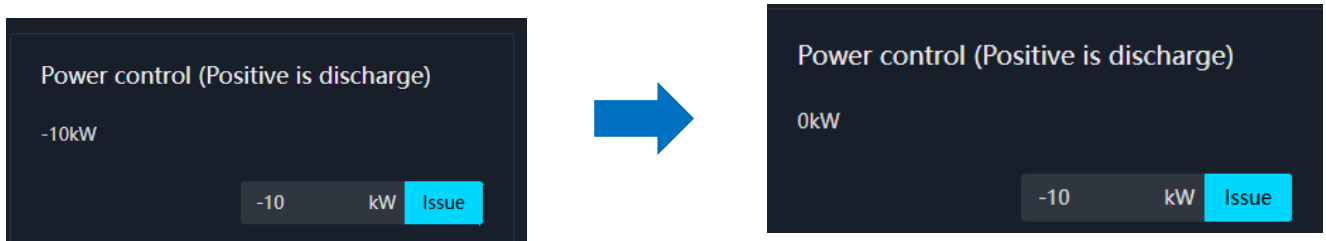

Step 4: Check the "Home" screen to verify that the PCS is in inactive mode, indicating that the equipment has been shut down.

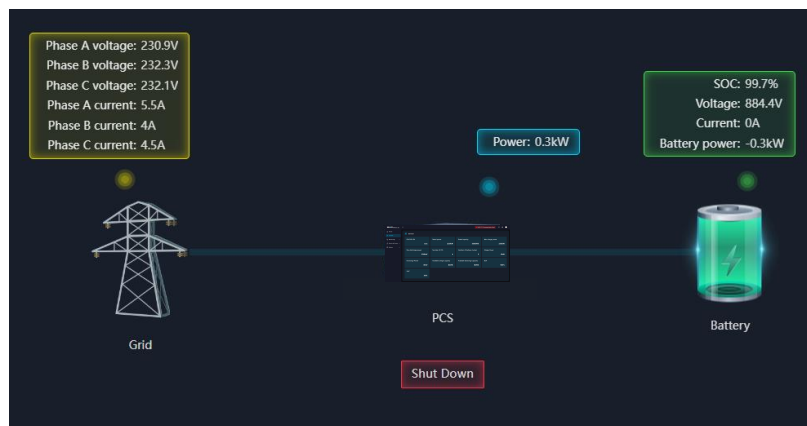

7 System Power-Off

BEWARE

When equipment installation and commissioning are completed, there is no need to breaker off the power supply to the system; simply follow the power-off procedure. If the equipment needs to be powered off for maintenance, please refer to the power-off procedure in this section.

Table 7-1 Power-Off Procedure

Step	Project	Comment
1	Turn off MCB4 and BCB5.	Press and hold "OFF" for 10 s until a "beep" sounds, then the UPS is Breakered off.
2	Turn off the circuit breaker groups MCB2 and MCB3 in sequence.	Deactivate the integrated distribution box EMS module and click the GN button.
3	AC input line QF	/
4	The battery cabinet is powered off.	Even after the equipment is powered off, the AC input line may still be live. Please take proper safety precautions.

Note a: After turn off the auxiliary communication circuit breaker (MCB3) of the battery cabinet, ensure that the power connection between the battery packs is also turn off to fully power down the DC side.

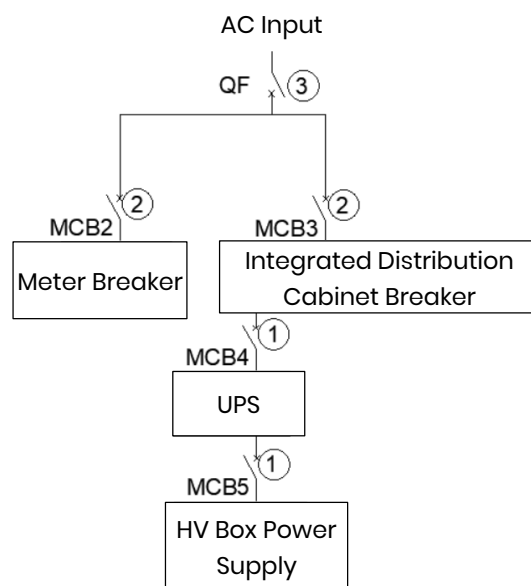

Figure 7-4 Power-Off Procedure

8 Technical Data

Table 8-1 AC-250kW-XXXX

Model	AC-250kW-1B10	AC-250kW-2B10	AC-250kW-4B10
AC Parameters (Grid-Connected)			
Rated input/output voltage [Vac]	3W+PE.400		
Rated input/output frequency [Hz]	50		
Rated input/output active power [kW]	237.2		
Maximum input/output apparent power [kVA]	250		
Rated input/output current [Aac]	342.4		
Maximum continuous input/output current [Aac]	360.8		
Auxiliary input voltage [Vac]	L+N 220/230		
Auxiliary input apparent power [kVA]	1		
Auxiliary input frequency [Hz]	50		
Power factor range	>0.99		
DC Parameters			
Battery type	Lithium-ion		
Battery voltage range [Voc]	650~900		
Number of DC branches	1	2	4
Maximum charge power [kW]	244	122	61
Maximum discharge power [kW]	254.8	127.4	63.7
Maximum charge/discharge current [Adc]	409.2	204.6	102.3
Basic parameters			
Operating temperature range [°C]	-25~60		
Topology	Non-isolated		

Protection class	Class I
Overvoltage category	II(DC)/III(AC)
Ingress protection	IP55

Table 8-2 AC-187kW-XXXX or AC-62.5kW-XXXX

Model	AC-187kW-1B10	AC-62.5kW-1B10
AC Parameters (Grid-Connected)		
Rated input/output voltage [Vac]	3W+PE.400	
Rated input/output frequency [Hz]	50	
Rated input/output active power [kW]	177.9	59.3
Maximum input/output apparent power [kVA]	187.5	62.5
Rated input/output current [Aac]	243.3	81.1
Maximum continuous input/output current [Aac]	270.6	90.2
Auxiliary input voltage [Vac]	L+N 220/230	
Auxiliary input apparent power [kVA]	1	
Auxiliary input frequency [Hz]	50	
Power factor range	>0.99	
DC Parameters		
Battery type	Lithium-ion	
Battery voltage range [Voc]	650~900	
Number of DC branches	1	1
Maximum charge power [kW]	183	91.5
Maximum discharge power [kW]	191.1	95.55
Maximum charge/discharge current [Adc]	306.9	153.4
Basic parameters		
Operating temperature range [°C]	-25~60	
Topology	Non-isolated	
Protection class	Class I	
Overvoltage category	II(DC)/III(AC)	
Ingress protection	IP55	

Table 8-3 AC-125kW-XXXX

Model	AC-125kW-1B10	AC-125kW-2B10
AC Parameters (Grid-Connected)		
Rated input/output voltage [Vac]	3W+PE.400	
Rated input/output frequency [Hz]	50	
Rated input/output active power [kW]	118.6	
Maximum input/output apparent power [kVA]	125	
Rated input/output current [Aac]	171.2	
Maximum continuous input/output current [Aac]	180.4	
Auxiliary input voltage [Vac]	L+N 220/230	
Auxiliary input apparent power [kVA]	1	
Auxiliary input frequency [Hz]	50	
Power factor range	>0.99	
DC Parameters		
Battery type	Lithium-ion	
Battery voltage range [Voc]	650~900	
Number of DC branches	1	2
Maximum charge power [kW]	122	61
Maximum discharge power [kW]	127.4	63.7
Maximum charge/discharge current [A _{dc}]	204.6	102.3
Basic parameters		
Operating temperature range [°C]	-25~60	
Topology	Non-isolated	
Protection class	Class I	
Overvoltage category	II(DC)/III(AC)	
Ingress protection	IP55	

9. Product Maintenance

9.1 Terminology Definition

- Normal operation: Refers to a system that operates daily.
- Intermittent operation: Refers to a system that operates at an irregular monthly frequency and cannot guarantee daily operation.
- Long-term storage: Refers to a battery system that has not been activated for more than 5 consecutive months (the battery system should be charged to 50% SOC before suspending use).

9.2 Requirements for Normal System Operation

- Perform battery maintenance on the system every 12 months to prevent battery damage. Refer to Section 9.6 for specific maintenance instructions.
- Conduct a patrol inspection for the ESS every 12 months (refer to Appendix 1) and maintain inspection records.

9.3 Requirements for Intermittent System Operation

- The requirements are the same as those for normal operation of the system.

9.4 Requirements for Long-Term System Storage

- Energy storage battery storage SOC range: 30%~50%. Avoid long-term storage of cells below 15% SOC. When batteries are not used for a prolonged time, Turn off power-consuming devices promptly.
- Conduct a patrol inspection for the ESS every 5 months (refer to Appendix 1) and maintain inspection records.
- Perform battery maintenance on the system every 5 months to prevent battery damage. (Refer to Section 9.6 for specific maintenance instructions).
- Before the first use of a long-term stored system, perform at least one full charge cycle to activate the battery system and restore battery performance to its optimal state.

Tips
Long-term storage of the ESS may lead to irreversible battery damage. It is important to ensure regular maintenance.

9.5 Battery Maintenance Instructions

To ensure the safe and reliable long-term operation of your ESS, please read and follow the instructions below:

Maintenance Procedure:

Scheme 1: This power saving scheme is recommended when the battery system is at a low SOC level.

1. Discharge the battery system to the cut-off condition (average cell voltage $<3.1\text{ V}$ or minimum voltage $<2.8\text{ V}$), then stop discharging and let it rest for 1 h.
2. Perform an automatic full charge on the battery system (maximum cell voltage $>3.65\text{ V}$). After charging is complete, let it rest for 1 h.
3. Discharge the battery system to 50% SOC and then stop discharging.

Scheme 2: This power saving scheme is recommended when the battery system is at a high SOC level.

1. Perform an automatic full charge on the battery system (maximum cell voltage $>3.65\text{ V}$). After charging is complete, let it rest for 1 h.
2. Discharge the battery system to the cut-off condition (average cell voltage $<3.1\text{ V}$ or minimum voltage $<2.8\text{ V}$), then stop discharging and let it rest for 1 h.
3. Charge the battery system to 50% SOC and then stop charging.

Tips

1. Before performing maintenance, verify that the environment and system are in a safe condition, with no alarms or faults present.
2. After completing battery maintenance on the ESS, you can notify Weiheng After-sales Service for free data analysis.

9.6 Liquid Chiller System Maintenance and Service Requirements

- a) The coolant recommended by Weiheng is SoluKing SK-E50-B -40°C.
- b) It is strictly forbidden to inspect or repair the unit while it is energized. Wait more than 15 min after the unit is powered off before repairing or disassembling the unit.
- c) Third-party coolants not approved by Weiheng are not recommended. If used, they must comply with the coolant standards specified in Table 9-1. Damage to the battery cabinet components caused by using coolants other than those recommended by Weiheng will not be covered by the warranty.
- d) The coolant is typically an alkaline solution, and its alkalinity will gradually diminish over time with use. It is recommended to check the coolant concentration every six months. If the pH falls below 6, please consult our customer service for assistance.
- e) Use disposable pH test strips for testing. Immerse the strip in the coolant for 0.5 s, then remove it and compare it to a standard color chart to determine the pH value.
- f) The coolant sample for testing can be collected by inserting an 8 mm OD tube into the inspection port.
- g) Sampling should be performed with the system powered off, and 20–30 mL of coolant is required for a single test. Excessive discharge of coolant may result in insufficient fluid in the chiller, which may affect normal operation.

Table 9-1 Coolant Requirements

Model/Spec	Value
pH	7.5-8.5
Conductivity	200-3000 $\mu\text{S}/\text{cm}$
Evaporation Residue	< 500 mg/dm ³
Deposition	< 3 mg/dm ³
Ca + Mg	0.5-2 mmol/l
Bicarbonate	1-5 mmol/dm ³ (60-300mg/dm ³)
Free Carbon Monoxide	< 10 mg/dm ³
Sulphide	< 0.01 mg/dm ³
Chlorides	< 50 mg/dm ³
Sulphates	< 250 mg/dm ³
Nitrates	< 25 mg/dm ³
Nitrite	< 0.1 mg/m ³

A Crimping OT/DT Terminals

OT/DT Terminal Requirements

- For copper core cables, please use copper terminals.
- For copper-clad aluminum cables, copper terminals are required.
- For aluminum alloy cables, use copper-aluminum transition terminals, or aluminum terminals with copper-aluminum transition pads.

BEWARE

- It is strictly forbidden to connect aluminum terminals directly to terminal blocks, as this may cause electrochemical corrosion and affect the reliable cable connection.
 - When using copper-aluminum transition terminals, or aluminum terminals with copper-aluminum transition pads, ensure compliance with IEC61238-1.
 - When using copper-aluminum transition pads, ensure proper orientation so that the aluminum side of the pad contacts the aluminum terminal, and the copper side contacts the terminal block.
-

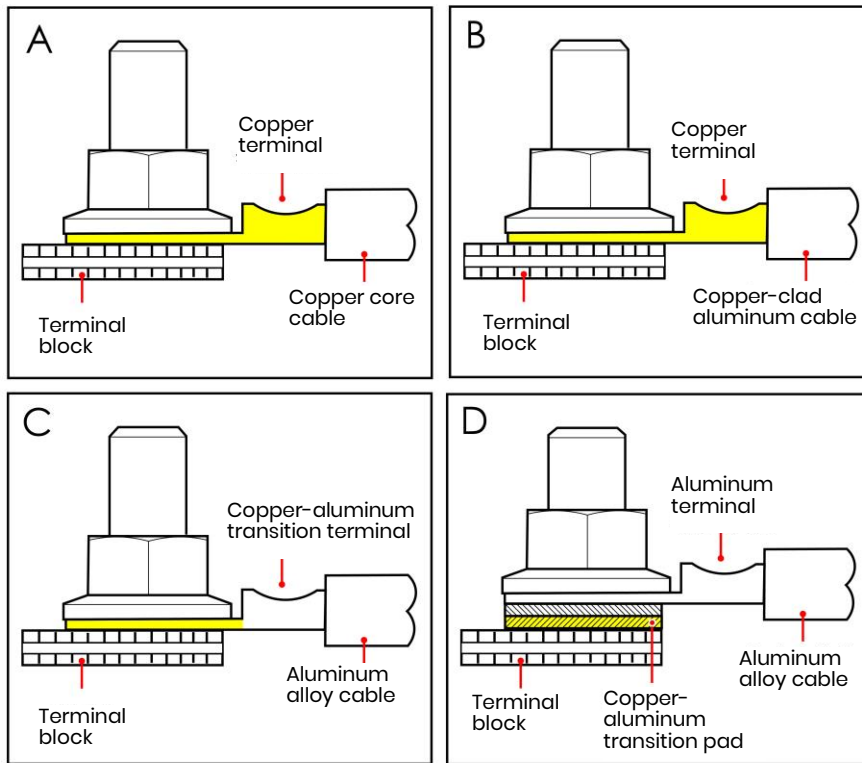

■ Figure A-1 OT/DT Terminal Requirements

Crimping OT/DT Terminals

BEWARE

- Do not scratch the conductor when stripping the cable.
- The cavity formed by the conductor crimping tab of the OT/DT terminal after crimping shall completely enclose the conductor, and the conductor shall be tightly connected to the OT/DT terminal without any looseness.
- The crimped area can be covered with heat shrink tubing or insulating tape. Below is an example of using heat shrink tubing.
- When using a heat gun, pay attention to safety precautions to prevent damage to the equipment.

Figure A-2 Crimping OT Terminal

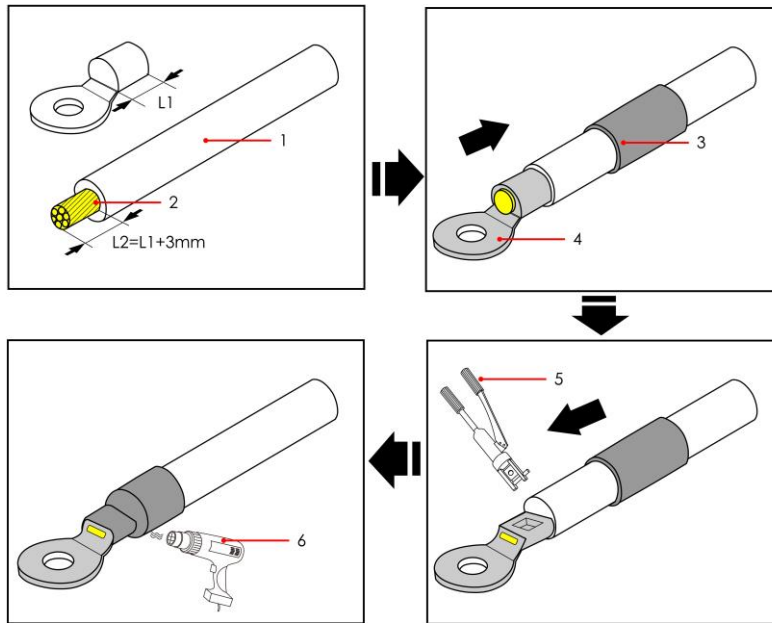

- (1) Cable
- (2) Conductor
- (3) Heat shrinks
- (4) OT terminal
- (5) Hydraulic crimping tubing pliers
- (6) Heat gun

Figure A-3 Crimping DT Terminal

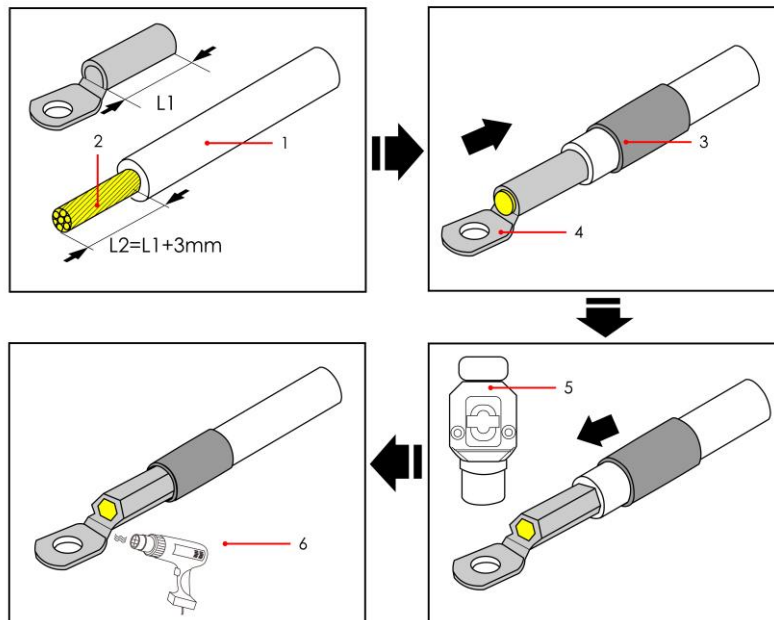

- (1) Cable
- (2) Conductor
- (3) Heat shrinks
- (4) DT terminal
- (5) Hydraulic crimping tubing pliers
- (6) Heat gun

B How to Repaint

Prerequisites

- Repainting outdoors without shelter is strictly prohibited in severe weather conditions such as rain, snow, strong winds, sandstorms.
- The paint required for repainting has been prepared according to the color chart delivered with the equipment.

Cabinet Color

- Enclosure and other sheet metal parts:
RAL 7035, small orange peel texture

Repainting Instructions

Maintain the intact appearance of the equipment by repainting any paint loss immediately.



Visually inspect the extend of paint damage and prepare the necessary tools and adequate materials according to actual needs on site.

Table A-1 Repainting Instructions

Paint Damage	Tools & Materials	Procedure	Description
Shallow scratches (without exposure of steel substrate)	Hand spray paint or paint, brush (for small area repainting), fine sandpaper, anhydrous ethanol, cotton cloth, spray gun (for large area repainting).	Follow Steps 1 + 2 + 4 + 5.	1. Use the color chart delivered with the equipment to match the topcoat (acrylic paint) color to the specified Pantone number. 2. For minor scratches, small stains, and rust, hand spray or brush painting is recommended. 3. For extensive scratches, large stains and rust, use a spray gun to apply the paint.
Non-wipeable stains and rust			
Deep scratches (primer damaged, steel substrate exposed)	Hand spray paint or paint, zinc-rich primer, brush (for small area repainting), fine sandpaper, anhydrous ethanol, cotton cloth, spray gun (for large area repainting).	Follow Steps 1 + 2 + 3 + 4 + 5.	4. Apply a thin, even coat of paint where practical, avoiding droplet formation and ensuring a smooth surface. 5. Allow the repainted surface to dry for approximately 30 min before proceeding with subsequent operations.
Logo and pattern damage or dents	For damaged logos and patterns, provide the logo dimensions and color code, and contact a local advertising and painting service provider to develop and execute a repair scheme based on the logo dimensions, color and damage situation. 1. For dents with an area less than 100 mm ² and a depth less than 3 mm, fill them with unsaturated polyester resin putty (Poly-Putty base) and then follow the repainting procedure for deep scratches. 2. For dents with an area greater than 100 mm ² or a depth greater than 3 mm, find a local supplier to provide a separate repair scheme based on the actual situation.		

Procedure

Step 1 Use fine sandpaper to gently sand the damaged area to remove any stains or rust.

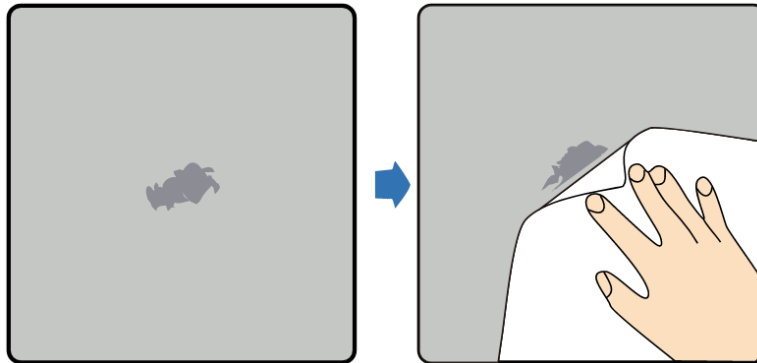

Figure B-1 Sanding Damaged Coating with Fine Sandpaper

Step 2 Wipe the sanded area or the area to be repaired with a cotton cloth dampened with anhydrous ethanol to remove surface dirt and dust. Then wipe it dry with a clean cotton cloth.

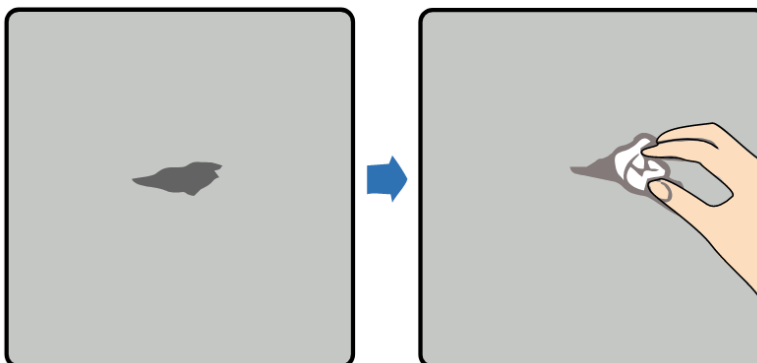

Figure B-2 Treating Damaged Coating with Anhydrous Ethanol

Step 3 Apply a zinc-rich primer to the damaged coating using a brush or spray gun.

i BEWARE

- If the substrate is exposed in the area to be repaired, apply an epoxy zinc-rich primer and allow it to dry completely to cover the substrate. Then apply an acrylic topcoat.
- Select an epoxy zinc-rich primer or acrylic topcoat of the appropriate color to match the surface finish of the equipment.

Step 4 Depending on the extent of the paint damage, choose one of the following methods: self-spraying, brushing, or spray gun application. Apply the paint evenly to the damaged area until no trace of coating damage is visible.

i BEWARE

- Apply a thin, even coat of paint where practical, avoiding droplet formation and ensuring a smooth surface.
- For equipment with multi-colored patterns, mask the areas with other colors using tape and white paper before repainting to prevent contamination.

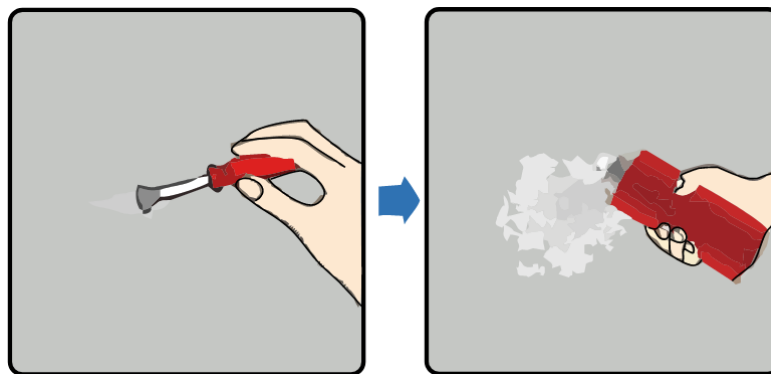

Figure B-3 Repainting Damaged Coating on Equipment

Step 5 Allow the brush-painted area to dry for approximately 30 min, then inspect for compliance with the requirements.

- The repainted area must match the color of the surrounding area. Use a colorimeter to measure the color difference ($\Delta E \leq 3$). If a colorimeter is unavailable, visually inspect the repainted area to ensure a seamless blend with the

surrounding area, free of any visible edge. The coating must be free of bumps, scratches, peeling, or cracks.

- For spray painting, it is recommended to spray three coats and then observe whether it meets the requirements. If not, repeat the spraying process until the requirements are met.

C How to Recycle Used Batteries

BEWARE

- Weiheng does not provide battery recycling services. Customers are responsible for contacting local recyclers for disposal.
- If no local service is available, customers are advised to contact the nearest national recycler for disposal.

Step 1 Contact the nearest recycler.

Step 2 The recycler evaluates the recycling cost.

Step 3 The recycler recycles batteries using one of the following two methods:

- On-site recycling: The recycler collects lithium batteries from the customer site, at a price determined based on the actual travel distance/transportation cost and other factors.
- Centralized recycling: The customer brings all lithium batteries to be recycled to a designated location for centralized collection by the recycler.

NOTE

Transportation cost arising from the on-site recycling service is to be borne by the customer.

Step 4 The recycler is fully responsible for the disposal of the recycled batteries. The recycler takes full responsibility for disposing of the recycled lithium batteries, with no further involvement from the customer.

D Contact Details

Please contact us if you have any questions about this product.

Table D-1 Customer Service Contact Details

Country	E-mail	Phone
China	service@whes.com	+86 4008776999

E Abbreviations

B

BMS Battery Management System

C

CAN Controller Area Network

E

ETH Ethernet Module

EMS Energy Management System

L

LAN local area network

S

SOC state of capacity

SBMU Secondary Battery Control Unit

U

UPS uninterruptible power system

F Install

Design requirements for foundation scheme:

- The energy storage system must be installed on a concrete or non-combustible surface. It is necessary to ensure that the installation plane is level, stable, flat, and has sufficient bearing capacity. There must be no depressions or tilts.
- The equipment foundation is configured based on the total weight of the equipment. If the local foundation's load-bearing capacity does not meet the requirements, it needs to be rechecked.
- The bottom of the equipment foundation pit must be compacted and leveled.
- After the equipment foundation is excavated, it is strictly prohibited to soak it and disturb it. If it is disturbed by soaking, it should continue to be excavated and backfilled.
- The horizontal error of the contact surface between the equipment foundation and the cabinet body must be $\leq 3\text{mm}$.
- The foundation must be higher than the local historical highest water level and at least 300mm higher than the horizontal ground.
- Drainage facilities should be constructed in combination with the local geological conditions and municipal drainage requirements to ensure that no water accumulation occurs at the equipment foundation. The foundation construction should meet the drainage requirements for the local maximum rainfall, and the discharged water needs to be treated in accordance with local laws and regulations.
- When constructing the equipment foundation, it is necessary to consider the possibility of problems with the cables of the energy storage system and reserve trenches or incoming line holes.
- The reserved holes for the equipment foundation and the incoming line holes at the bottom of the equipment should all be sealed.
- The foundation drawing cannot be used as the final construction drawing and is for reference only. Users must recheck the design parameters of the energy storage system foundation according to the installation environment, geology, and seismic requirements

of the project site.

BEWARE

- When installing the Battery Cabinet and AC Cabinet, from the front of the equipment, It is recommended to place AC Cabinet on the right side of Battery Cabinet.
- The following figure shows the minimum space requirements for installation and operation maintenance.

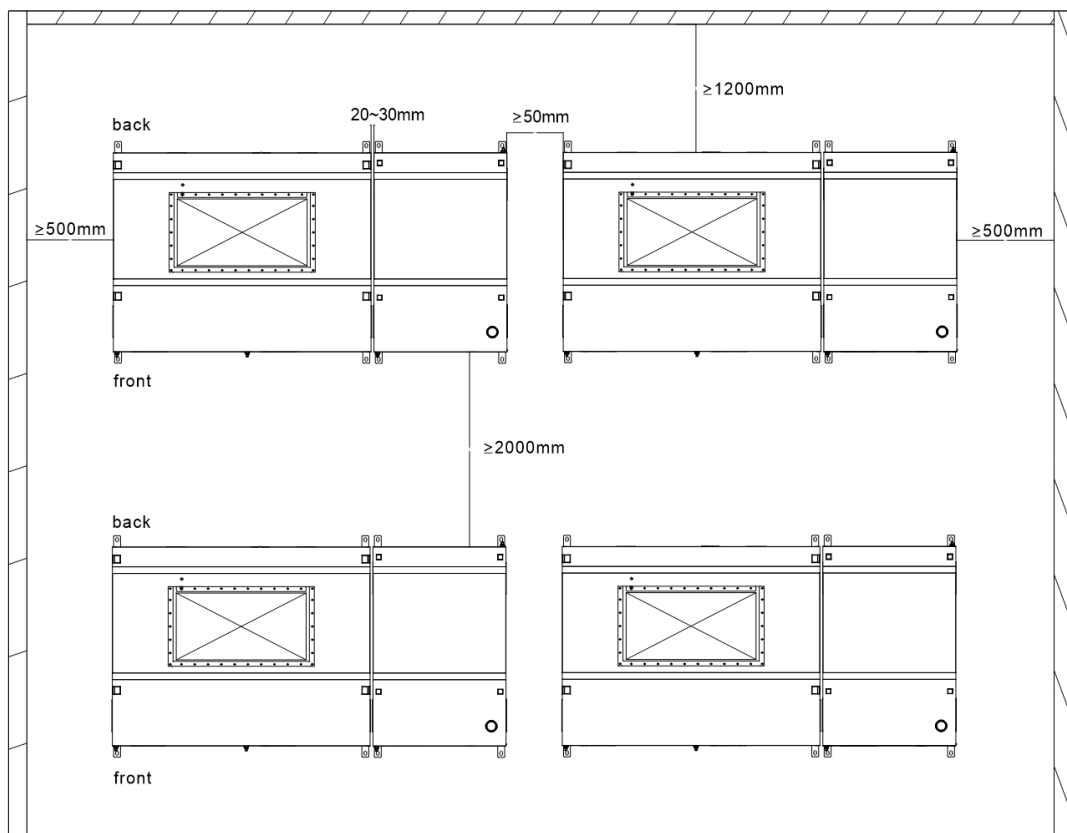

Figure F-1 Side-by-side installation (top view)

BEWARE

● Regarding the installation layout of on-site equipment, the face-to-face installation mode is not recommended. If this installation method must be used due to special circumstances, please contact our company's after-sales personnel in advance to visit the site for evaluation.

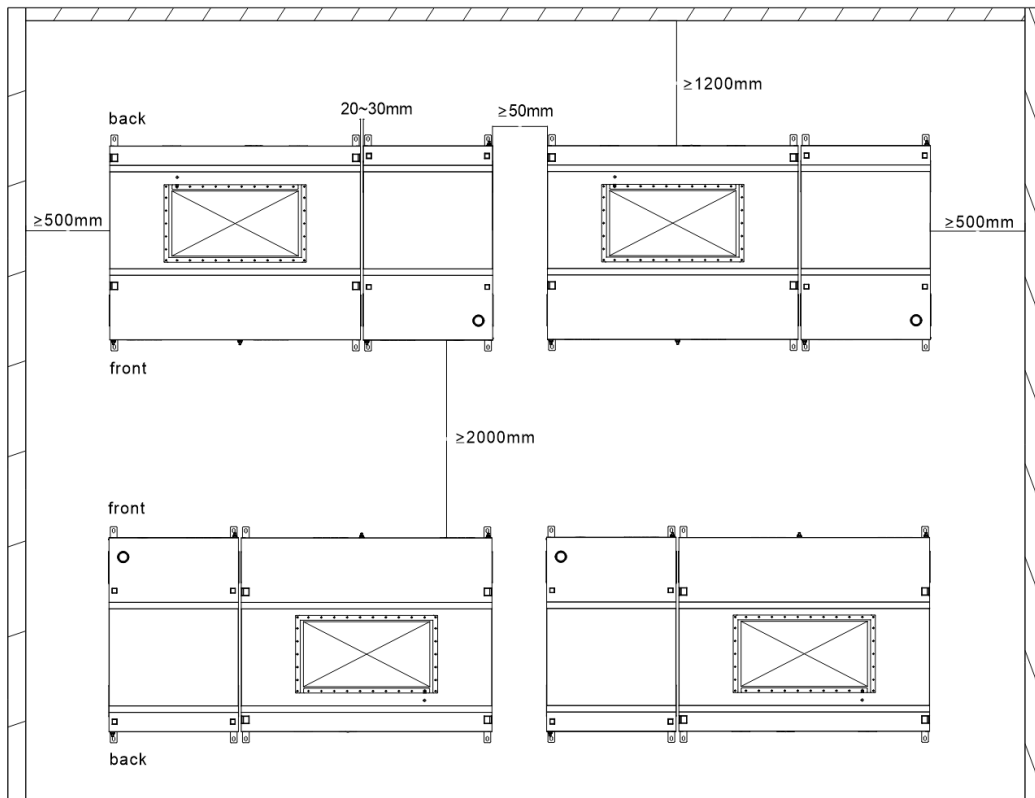
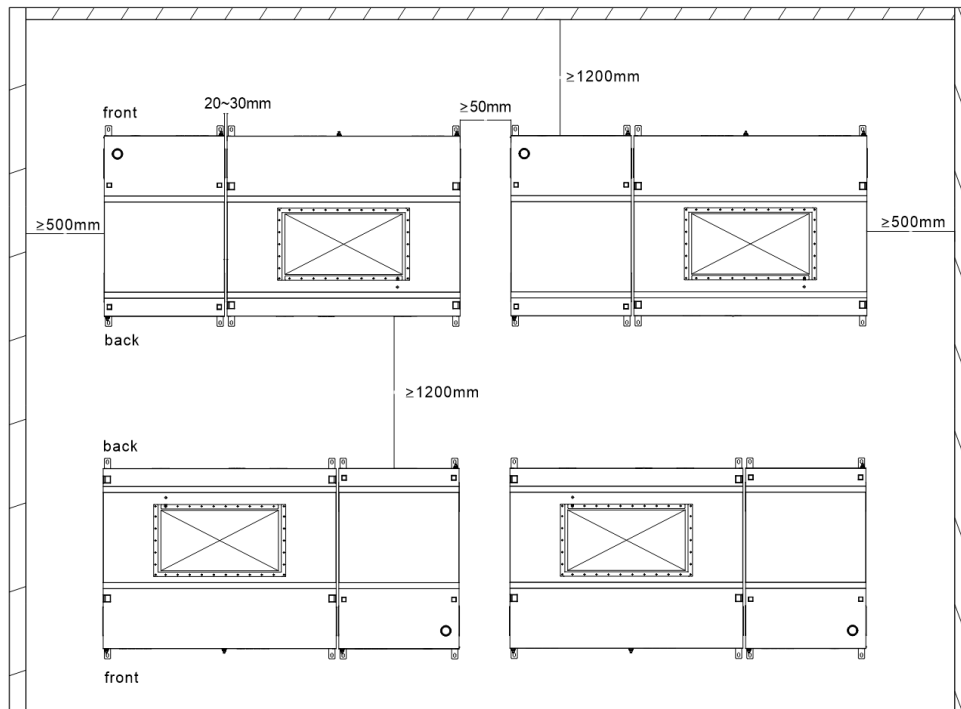

Figure F-2 Face-to-face installation (top view)



■ Figure F-3 Back-to-back installation (top view)

Equipment Installation Instructions

- **Distance between the equipment and the wall:** The horizontal distance between the two sides (lateral sides) of the equipment and the surrounding walls should be $\geq 500\text{mm}$ to ensure there is enough space for installation, operation, and maintenance.
- **Horizontal spacing between equipment:** If the equipment is installed side by side horizontally, the spacing between them should be controlled at 20 - 30mm; if the equipment is adjacent to other equipment (not side - by - side), the spacing should be $\geq 50\text{mm}$.
- **Vertical spacing between upper and lower rows of equipment:** The vertical distance between the upper and lower rows of equipment must be $\geq 2000\text{mm}$ to meet the space requirements for installation, debugging, and subsequent maintenance. (If the equipment is arranged in a back - to - back installation method, the installation distance between the upper and lower rows can be reduced to $\geq 1200\text{mm}$)

Appendix 1

附录 1

巡检项目 Inspection project	方法 Method	是-√ 否-× 不适用-O Yes-√ No-× Not applicable-O	异常记录 Abnormal record
灭火系统是否完整 Is the fire extinguishing system	目测 Visual inspection		
灭火系统是否在有效期内 Whether the fire extinguishing system is within the validity period	目测 Visual inspection		
散热系统是否完整 Is the chiller system complete	目测 Visual inspection		
散热系统风道是否堵塞 Is the chiller system air duct blocked	目测 Visual inspection		
电柜外观是否变形 Whether the appearance of the electric cabinet is deformed	目测 Visual inspection		
电柜外观是否生锈破损 Whether the appearance of the electric cabinet is rusted or damaged	目测 Visual inspection		
电柜内部是否有水气 Is there water vapor inside the electric cabinet	目测 Visual inspection		
低压线束是否松脱或者破损 Whether the LV harness is loose or damaged	目测 Visual inspection		
高压线束是否松脱或者破损 Whether the HV harness is loose or damaged	目测 Visual inspection		
线束是否与结构件干涉 Whether the wiring harness interferes with the structural parts	目测 Visual inspection		
高压连接是否烧蚀 Whether the high voltage connection is ablated	目测 Visual inspection		

结构件固定螺栓是否松脱或者缺失 Whether the fixing bolt of structural parts is loose or missing	目测 Visual inspection		
液冷管是否破损 Whether the water cooling pipe is damaged	目测 Visual inspection		
电池室内是否有恶臭味 Is there a foul smell in the battery compartment	鼻嗅 Sniffing		
电柜内有无刺激性气味 Is there a pungent smell in the electric cabinet	鼻嗅 Sniffing		
高压连接部位是否有烧焦味 Whether HV connection part has burnt smell	鼻嗅 Sniffing		
概要数据是否齐全 Is the summary data complete	监控上位机 Monitor master computer		
单体电压数据是否齐全 Is the cell voltage data complete	监控上位机 Monitor master computer		
单体温度数据是否齐全 Is the cell temperature data complete	监控上位机 Monitor master computer		
告警栏有无异常报警 Whether there is an abnormal alarm in the alarm bar	监控上位机 Monitor master computer		
<p>说明：巡检中发现任何异常请及时反馈，联系安排相关人员进行处理 Note: If any abnormalities are found during the inspection, please feedback in time, and contact the relevant personnel for processing.</p>			